



MōVI<sup>PRO</sup>

# OPERATION MANUAL

To download the most current user manual for the MōVI Pro and all other Freefly products, please visit <http://freeflysystems.com/software-manuals>



@freeflysystems | #freeflyers

# REVISION HISTORY

---

REVISION	DATE	DESCRIPTION
A	Nov 2016	Initial Release

---

# CONTENTS

---

3	Revision History
4	Contents
6	Terminology
8	<b>OVERVIEW</b>
9	Disclaimer and Warning
13	Limitations of Liability
14	Warranty
16	Introduction
17	Features
19	Getting to Know MōVI Pro
20	GCU and TSU Layouts
22	Tilt Stage Unit
23	Gimbal Control Unit connectors and piNouts
24	Tilt Stage Unit connectors and pinouts
28	System Diagrams
28	MōVI Pro Overview
29	MōVI Pro Control Paths
30	MōVI Pro Power System
31	MōVI Pro + Mimic
32	MōVI Pro App
33	MōVI Pro Kit
34	<b>SETTING UP MōVI PRO</b>
35	MōVI Pro Setup at a Glance
36	Toad In The Hole Quick Release
39	Charging Batteries
41	Setting Up Your Camera Package
41	Basic Setup
43	Advanced Setup
48	Setting Up FIZ
50	Attaching a Transmitter
52	Mounting a Monitor

53	Mounting the Camera package
55	Battery Installation and RED, ARRI, SONY, CANON Wiring
56	Freely Cable Guide
59	Balancing the MōVI Pro
63	Tuning the MōVI Pro
63	Basic Tuning
64	Advanced Tuning
67	Updating the MōVI Pro
68	Ecosystem Setup
68	MIMIC + MōVI Pro
69	MIMIC Beta + MōVI Pro
71	MōVI CONTROLLER + MōVI Pro
73	Futaba or Spektrum Radio + MōVI Pro
73	Multi Controller Setup
74	ALTA + MōVI Pro
78	TERO + MōVI Pro

## 80 **USING MōVI PRO**

81	Configuring the MōVI Pro
82	Apps and Software
87	Setting Configuration via the Freely MōVI Pro App
90	FIZ Setting Configuration via the MōVI Controller
92	Modes

## 99 **TROUBLESHOOTING AND MAINTENANCE**

100	Troubleshooting Guide
-----	-----------------------

## 102 **APPENDIX**

103	Default Tuning Values
105	Data Logging Fields

# TERMINOLOGY

---

2.4 GHz	An industrial, scientific, and medical (ISM) radio band (2.4-2.5GHz) that is used for radio control.
Accelerometer	An accelerometer is a device that measures the rate of change of the velocity of an object.
Amperage	The strength of an electric current going through a system, expressed in amps.
BLE	Bluetooth Low Energy (BLE) is a low power and application friendly version of Bluetooth.
FIZ	An acronym for focus, iris, and zoom in reference to lens control.
FPS	Frames per second (FPS) also known as frame frequency, is the frequency at which an imaging device displays consecutive images called frames.
GCU	Gimbal Control Unit (GCU) refers to the MōVI Pro's central processor and housing, which is attached to the pan arm.
GPS	Global Positioning System (GPS) is a satellite-based navigation system made up of a network of 31 satellites that can be used to determine global position.
Gyro	Gyros are sensors that measure the angular velocity of an object they are mounted on.
HACC	A GPS value indicating the horizontal accuracy (HACC) of the position fix.
HDMI	High-Definition Multimedia Interface (HDMI) is an audio/video interface for transferring uncompressed video data and compressed or uncompressed digital audio data.
Hot Shoe	The Hot Shoe is a mounting point on the top of a camera where compatible accessories can be mounted.
INS	An inertial navigation system (INS) is an electronic device that measures and reports a body's specific force, position, angular rate, and sometimes the magnetic field, using a combination of accelerometers, compasses, magnetometers, gyroscopes, and GPS.
Motor Drive	A motor drive is an electronic circuit which can vary an electric motor's position and speed through pulse width modulation.
MEMS	Acronym referring to Microelectromechanical Systems (MEMS).
RCP	REDLink Command Protocol (RCP) is the unified command protocol used for the RED EPIC and SCARLET cameras, regardless of sensor type.
RX	RX is an acronym for receive, receiver, or reception.

TITH	Toad in the Hole (TITH) is a lightweight and low-profile mechanical quick release unit used on Freely products.
TSU	Tilt Stage Unit (TSU) is the platform underneath the camera mount on the MōVI Pro that provides orientation feedback to the GCU and can provide power and control to the camera and mounted accessories.
TX	TX is an acronym for transmit or transmitter.
uART	A universal asynchronous receiver/transmitter (uART) is a block of circuitry responsible for implementing serial communication.
Voltage	The electromotive force or potential difference in an electrical system, expressed in volts.



# OVERVIEW



# DISCLAIMER AND WARNING

---

**IMPORTANT** - Please read this disclaimer and warning carefully, and review the MōVI Pro Gimbal Operation Manual prior to use. If you have any questions, please contact [support@freeflysystems.com](mailto:support@freeflysystems.com) prior to using the MōVI Pro. You can review the most current version of this Operation Manual at [www.freeflysystems.com/software-manuals](http://www.freeflysystems.com/software-manuals).

By using MōVI Pro, you acknowledge that you have read, understand, and agree to this disclaimer. You agree that you are solely responsible for your conduct while using MōVI Pro and for any direct or indirect consequences that may result from its use.

Freely Systems reserves the right to revise this Operation Manual and make changes from time to time without obligation to notify any persons of such revisions or changes. In no event shall Freely Systems, its employees or authorized agents be liable for any damages or losses, direct or indirect, arising from the use of any technical or operational information contained in this document.

- » Always check MōVI Pro and its components prior to operation.
- » Always maintain awareness of your surroundings when operating MōVI Pro.
- » It is your responsibility to perform a full system check of MōVI Pro prior to every use.
- » It is your responsibility to learn how to safely operate MōVI Pro.
- » MōVI Pro is a tuned system with custom components selected for each application. Modification to, removal, or substitution of MōVI Pro components will void the warranty.
- » It is your responsibility to create shots that amaze the world.

## BATTERIES AND CHARGING

You must read these safety instructions and warnings carefully before charging or using your MōVI Pro Battery Pack. Failure to exercise caution while using the MōVI Pro Battery Pack, a Lithium Polymer (LiPo) battery, and failure to comply with the following warnings can result in battery malfunction, electrical issues, excessive heat, fire, personal injury, and/or property damage.

### BATTERY SAFETY AND WARNINGS

You must read these safety instructions and warnings carefully before charging or using the MōVI Pro Battery Pack. Improper use may result in damage to the batteries, severe personal injury, and/or fire.

- » Do not leave the MōVI Pro Battery Packs and charger unattended during use.
- » Stop using or charging the MōVI Pro Battery Pack immediately if the battery pack becomes or appears damaged, starts to balloon or swell, leaks, becomes deformed or gives off an odor, exceeds a temperature of 140°F (60°C), or if anything else abnormal occurs. Disconnect the battery and observe in a safe area outside of any building or

vehicle for at least 45 minutes, as a damaged battery can experience a delayed chemical reaction that could possibly result in fire.

- » Never disassemble, modify, puncture, shock, crash, short circuit, and/or expose the MōVI Pro Battery Packs to a flame. Leakage, smoke emission, ignition, explosion or fire can occur, which may result in personal injury or property damage.
- » Never drop the charger or MōVI Pro Battery Packs.
- » Never allow an electrical short between the battery's positive and negative terminals.
- » Never allow minors to charge or use MōVI Pro Battery Packs without adult supervision.
- » Never allow MōVI Pro Battery Packs to come in contact with moisture at any time.
- » Never leave MōVI Pro Battery Packs in an automobile or direct sunlight.
- » Never place or carry MōVI Pro Battery Packs in your pockets or clothing.
- » Always use MōVI Pro Battery Packs to power MōVI Pro. Alternate batteries are not supported.
- » MōVI Pro Battery Packs should be stored in a vented, fire-proof container. No more than two MōVI Pro Battery Packs should be placed in a container to avoid chain reactions. The recommended storage temperature range is 10°C to 26°C. Exposure to high temperatures may cause fire, even with undamaged MōVI Pro Battery Packs.
- » Never charge or store MōVI Pro Battery Packs in extreme heat (>30°C) or cold (<0°C).
- » Do not store fully charged MōVI Pro Battery Packs for long periods of time.
- » Damaged batteries are extremely sensitive to temperature fluctuation and care should be taken in their immediate disposal.
- » Do not discharge MōVI Pro Battery Packs with current exceeding the 8-10A of continuous discharge current. It will cause the battery to overheat and may result in battery deterioration, swelling, bursting, or fire.
- » Always discharge in a fireproof location.
- » In purchasing MōVI Pro Battery Packs as part of MōVI Pro, the buyer agrees to bear all responsibilities of the risks and not hold Freely Systems, its owners and employees, its distributors, and/or its retailers responsible for any accidents, injury to persons, and property damage. If you do not agree to these conditions, please return the MōVI Pro and MōVI Pro Battery Packs to the place of purchase in a new and unused condition.



All instructions and warnings must be followed exactly. Mishandling of MōVI Pro Battery Packs can result in fire. By handling, charging, or using the included MōVI Pro Battery Packs, you assume all risks associated with MōVI Pro Battery Packs. If you are not prepared to accept complete liability for the purchase and/or use of the batteries, you are advised to return them in new and unused condition to the place of purchase immediately.

## CHARGING PROCEDURE SAFETY AND WARNINGS

You must read these safety instructions and warnings carefully before charging your MōVI Pro Battery Packs.

- » Always charge MōVI Pro Battery Pack with MōVI Pro Battery Charger. An unqualified charger may cause damage to the batteries or a fire.
- » Never charge or use a MōVI Pro Battery Pack that shows any damage or disfigurement of any kind, as this may be a sign of internal damage. Any damage to the protective cover or connector is also reason to discontinue use.
- » Do not leave MōVI Pro Battery Packs unattended while charging.
- » Always inspect MōVI Pro Battery Packs before charging.
- » Never charge near moisture, extreme temperatures, flammable or combustible materials.
- » Never charge a MōVI Pro Battery Pack while inside a vehicle.
- » Never attempt to charge a MōVI Pro Battery Pack that is damaged or is completely dead.
- » Always monitor the temperature of the MōVI Pro Battery Pack while charging. If the MōVI Pro Battery Pack becomes hot to the touch or begins to deform, discontinue charging immediately. Disconnect the battery from the charger and observe it in a safe place for at least 45 minutes.

## BATTERY DISPOSAL PROCEDURE

LiPo batteries require special handling for safe disposal. The following steps must be taken to avoid damage or injury to yourself, your property or anyone who comes in contact with the battery.

1. Contact your state or local HAZMAT agency inquire about disposal procedures for LiPo batteries with battery management systems.
2. Follow any instructions provided by your state or local HAZMAT agency for the disposal of LiPo batteries.



Do not transport or ship batteries which have more than 1.0V per cell charged or show signs of damage without following the instructions given by the HAZMAT agency

# LIMITATIONS OF LIABILITY

---

IN NO EVENT SHALL FREEFLY SYSTEMS BE LIABLE TO THE BUYER FOR ANY INDIRECT, CONSEQUENTIAL, PUNITIVE, INCIDENTAL, OR SPECIAL DAMAGES, OR ANY DAMAGES WHATSOEVER RESULTING FROM THE USE OF PRODUCT OR FROM LOSS OF USE, DATA OR PROFITS (HOWEVER CAUSED AND UNDER ANY THEORY OF LIABILITY), EVEN IF FREEFLY HAS BEEN ADVISED OF THE POSSIBILITY OF SUCH DAMAGES. IN NO EVENT SHALL FREEFLY'S LIABILITY FOR A PRODUCT (WHETHER ASSERTED AS A TORT CLAIM, A CONTRACT CLAIM OR OTHERWISE) EXCEED THE AMOUNTS PAID TO FREEFLY FOR SUCH PRODUCT. NOTWITHSTANDING ANYTHING HEREIN, IN NO EVENT SHALL FREEFLY'S LIABILITY FOR ALL CLAIMS ARISING OUT OF OR RELATING TO THIS AGREEMENT EXCEED THE AMOUNTS PAID BY BUYER TO FREEFLY FOR PRODUCT IN THE LAST TWELVE (12) MONTHS. IN NO EVENT WILL FREEFLY OR ITS LICENSORS BE LIABLE FOR COSTS OF PROCUREMENT OF SUBSTITUTE GOODS BY BUYER. IN NO EVENT WILL FREEFLY OR ITS LICENSORS BE LIABLE FOR DAMAGES ARISING OUT OF ANY LATE DELIVERY. THE LIMITATIONS SET FORTH HEREIN SHALL APPLY TO ALL LIABILITIES THAT MAY ARISE OUT OF THIRD-PARTY CLAIMS AGAINST BUYER. THESE LIMITATIONS SHALL APPLY NOTWITHSTANDING ANY FAILURE OF ESSENTIAL PURPOSE OF ANY LIMITED REMEDY. THE LIMITATION SET FORTH IN THIS SECTION SHALL APPLY WHERE THE DAMAGES ARISE OUT OF OR RELATED TO THIS AGREEMENT.

Freefly shall not be liable for damages or injuries incurred directly or indirectly from the use of MōVI Pro including, but not limited to, the following situations:

- » Failure of operator to follow proper instructions and safety warnings found at [www.freeflysystems.com](http://www.freeflysystems.com).
- » Failure of the operator to understand and operate the gimbal within the operating limitations described in this manual.
- » Failure of the operator to follow onboard safety warnings while using MōVI Pro.
- » Failure of the operator to inspect MōVI Pro and its components prior to operation.
- » Failure of the operator to properly maintain and/or service MōVI Pro through an authorized Freefly Service Center with genuine MōVI Pro parts.
- » Use of third-party products on MōVI Pro.
- » Use of MōVI Pro in unsafe conditions, including but not limited to, bad or severe weather, such as rain, wind, snow, lightning, dust storms, etc.
- » Improper operation, misjudgment or risky behavior while using MōVI Pro.
- » Infringement of third party data, audio or video rights recorded when using MōVI Pro.

# WARRANTY

---

## SPECIFICATIONS

Freefly warrants all products will be of good quality and workmanship and free from material defects. Upon the expiration of the time periods below, all liabilities of Freefly will terminate. In no event shall Freefly be liable for consequential damages. Freefly may use refurbished parts for repairs or replacements. Certain products may be subject to a separate software license agreement.

## STANDARD WARRANTY

A Standard Warranty is granted to the original purchaser by Freefly for a period of one (1) year, parts and labor. The Standard Warranty does not apply to MōVI Pro Battery Packs. The Standard Warranty covers parts and labor charges for Product that has been returned with pre-paid shipment to an Authorized Service Center by Buyer. Service or replacement decisions are at the sole discretion of Freefly. Proof of purchase is required for warranty claims. All warranty returns shall be done in accordance with Freefly's warranty Return Merchandise Authorization (RMA) policy, which can be found on our website. Any repaired or replaced Product shall be warranted as set forth in this section for a period the greater of (a) the balance of the applicable warranty period relating to such Product or (b) ninety (90) days after it is received by Buyer. Only the components that were repaired or replaced will be eligible for the 90-day period as set forth above. The Standard Warranty effective date is the date of "ex works" from Woodinville, Washington.

## EXCLUSIVE BATTERY WARRANTY

Freefly warrants that MōVI Pro Battery Packs purchased or included with the Product will be free from defects in materials and workmanship at the date of purchase by Buyer. Battery product warranty is limited to original defects in material and workmanship. Due to the nature and use of these batteries, there is no term warranty. Misuse, abuse, incorrect charging, failure to comply with applicable battery warnings and guidelines, and other inappropriate use of the batteries are not covered under this warranty.

## WARRANTY LIMITATIONS

All Freefly warranties do not cover (a) maintenance, repair or replacement necessitated by loss or damage resulting from any cause other than normal use and operation of the Product in accordance with Freefly's specifications and owner's manual, including but not limited to: theft, exposure to weather conditions, operator negligence, misuse, abuse, improper electrical/power supply; (b) alterations, modifications or repairs by Buyer or unauthorized third parties; (c) accident, disaster, improper handling or storage, droppage, modification, opening sealed components, use of third party accessories or acts of nature or any other peril originating from outside the Product; (d) transportation damage, lack of or improper maintenance, defective batteries, battery leakage; and (e) cosmetic damage or other non-operating parts. Removal or modification of sealed components, including but not limited to, motors or electronics, voids any and all warranties. Breaking the seal on any sealed components, including but not limited to motors or electronics, is prohibited and voids any and all warranties unless otherwise approved by Freefly. Any parts replaced by Freefly during warranty repair are the property of Freefly and will

not be returned to Buyer. Freely may use refurbished parts for repairs or replacements.

Freely products are compatible with Freely software, Freely parts and Freely products only. Use of any software, parts, or products, other than Freely or Freely approved software, parts, and products, which plug into or directly affect the function or performance of Freely products voids any and all warranties.

### **LIMITATION OF LIABILITY**

EXCEPT AS SPECIFICALLY SET FORTH ABOVE, FREEFLY AND ITS LICENSORS MAKE NO WARRANTIES, CONDITIONS, REPRESENTATIONS OR TERMS, EXPRESS OR IMPLIED, WHETHER BY STATUTE, COMMON LAW, CUSTOM, USAGE OR OTHERWISE AS TO THE FREEFLY PRODUCT OR ANY COMPONENT THEREOF, INCLUDING BUT NOT LIMITED TO NON-INFRINGEMENT OF THIRD PARTY RIGHTS, INTEGRATION, MERCHANTABILITY, SATISFACTORY QUALITY, OR FITNESS FOR ANY PARTICULAR PURPOSE. FREEFLY AND ITS LICENSORS DO NOT WARRANT THE PERFORMANCE OR RESULT OF THE FREEFLY PRODUCT. THE SOLE REMEDY UNDER THIS WARRANTY SHALL BE THE REPAIR OR REPLACEMENT FOR DEFECTIVE PARTS AS STATED ABOVE. THIS WARRANTY IS THE SOLE WARRANTY GIVEN BY FREEFLY AND IS IN LIEU OF ANY OTHER WARRANTIES EITHER EXPRESS OR IMPLIED. THIS WARRANTY EXTENDS TO THE BUYER AND IS NON-TRANSFERABLE TO OTHER THIRD PARTIES. FREEFLY SHALL NOT BE LIABLE FOR SPECIAL, INDIRECT, INCIDENTAL OR CONSEQUENTIAL DAMAGES, LOSS OF PROFITS OR PRODUCTION OR COMMERCIAL LOSS IN ANY WAY, REGARDLESS OF WHETHER SUCH CLAIM IS BROUGHT IN CONTRACT, WARRANTY, TORT, NEGLIGENCE, STRICT LIABILITY OR ANY OTHER THEORY OF LIABILITY, EVEN IF FREEFLY HAS BEEN ADVISED OF THE POSSIBILITY OF SUCH DAMAGES. IN NO EVENT SHALL THE LIABILITY OF FREEFLY EXCEED THE INDIVIDUAL PRICE OF THE PRODUCT ON WHICH LIABILITY IS ASSERTED.

### **THIRD PARTY WARRANTY**

Freely does not honor warranty agreements extended by third parties. Only warranty agreements granted by Freely will be honored by Freely.

### **NON-WARRANTY REPAIR**

Product that no longer qualifies for Warranty Repair may be sent to an Authorized Freely Service Center subject to an evaluation fee. Freely will provide a quotation for the repair of the Product. The Customer is responsible for all costs associated with such refurbishment, such as troubleshooting, diagnosis, repair, test, calibration, storage, and shipping costs. The evaluation fee will be applied to the cost of the refurbishment if the cost of the refurbishment is greater than the evaluation fee. Any repaired or replaced product shall be warranted for ninety (90) days after it is received by Buyer. Only the components that were repaired or replaced will be eligible for the 90-day period. Any parts replaced by Freely during non-warranty repair are the property of Freely and will not be returned to Buyer. Freely may use refurbished parts for non-warranty repair.

### **LAW GOVERNING**

These terms are governed by Washington State law (without regard to conflict of law principles or the United Nations Convention on Contracts for the International Sale of Goods.) Freely reserves the right to change or modify this warranty at any time without notice. For up-to-date warranty information, visit [www.freelysystems.com](http://www.freelysystems.com).

# INTRODUCTION

---

The Freefly MōVI Pro represents the next generation of digital 3-axis stabilization systems. Designed and built with the goal of creating the world's most versatile camera movement system, the MōVI Pro will revolutionize and democratize the creation of professional motion picture content. Using active and inertial stabilization, the MōVI Pro allows filmmakers precise, intuitive, and creative control of the camera, and its new features grant even more possibilities to create world-class content quickly and easily.

This manual will teach you how to set up, balance, and tune your MōVI Pro. It also includes detailed descriptions of the MōVI Pro's features and capabilities to familiarize you with the possibilities of using it in conjunction with the rest of the Freefly ecosystem of products.

## WARNINGS, CAUTIONS AND NOTES

Throughout the manual, warnings, cautions and notes are used to highlight various important procedures. These are defined as follows:



### WARNING

Warnings are used to highlight procedures which, if not strictly observed, may result in personal injury or loss of life.



### CAUTION

Cautions are used to highlight procedures which, if not strictly observed, may cause damage to equipment.

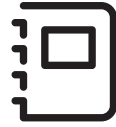

### NOTE

Notes are used to highlight specific operating conditions or steps of a procedure.



# FEATURES

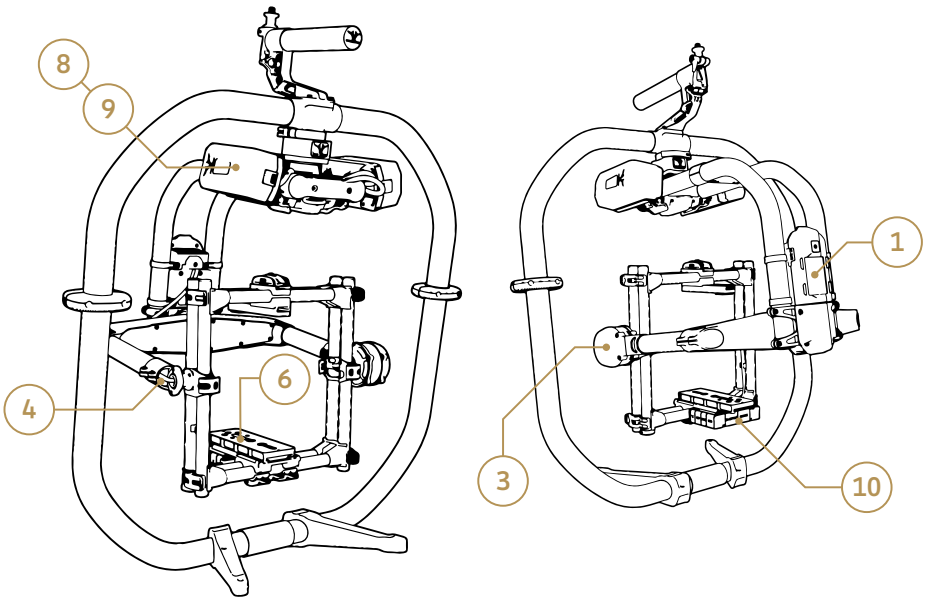

## MECHANICAL FEATURES

- 1. Built-in Display** The addition of a built-in display with a 4-button control system gives users command over basic tuning and adjustments without the need for additional devices.
- 2. Redesigned Structure** A redesigned structure improves performance and adds features to increase the MōVI Pro's capabilities.
- 3. Increased Torque** New, lightweight direct-drive brushless motors provide twice the pan torque of the first generation MōVI.
- 4. Internal Wiring** Updated wiring is now internally routed and strain relieved, preventing damage to cables and enhancing reliability in a variety of weather conditions.
- 5. Aerial Ready** Go from handheld to aerial in less than 60 seconds; with dual GPS antennas, lightweight construction, high torque motors, and an integrated FIZ driver, the MōVI PRO is unmatched in aerial performance.
- 6. Camera Rail** The addition of dovetails, revised camera mounts, easier top mounting, and a wide-body design results in an ultra versatile, lightweight camera rail that can easily be mounted and removed.
- 7. Rugged System** Designed as a precision instrument with the toughness to withstand every environment from the set to the outdoors.

## POWER FEATURES

- 8. Intelligent Batteries** Brand new MōVI Pro Battery Packs come with built-in power indicators, intelligent battery management systems, and a refined new design.
- 9. Hot Swapping** One handed battery swaps and hot swapping are now possible through a redesigned battery system which is built to keep the MōVI Pro shooting.
- 10. Camera and Accessory Power** Using the combined power of two 22.2V batteries, the MōVI Pro can power itself, the camera, and more for over an hour.

## CONTROL FEATURES

- 11. REDLink Command Protocol** Integrated REDLink Command Protocol grants users full control over RED EPIC and SCARLET camera adjustments, even when the user is hundreds of feet away from the mounted camera.
- 12. FIZ Control** Utilizing the world's smallest fully integrated 3-axis FIZ controller, the MōVI Pro reduces shooting weight and FIZ setup time with all industry standard motors.

## SOFTWARE FEATURES

- 13. MōVI Pro App** Using new Bluetooth Low Energy (BLE) technology users can connect to their MōVI Pro instantly from within the Android or iOS app to update, tune, adjust, and monitor the MōVI Pro.
- 14. Instant Booting** Advances in sensor initialization allow ultra fast boot times, maximizing productivity and minimizing downtime.
- 15. Autotuning** MōVI Pro is the first gimbal that requires no user tuning of filters or stiffness; its high performance tuning algorithms achieve optimum filters and stiffness in ~10 seconds.
- 16. Stability Improvements** Refined software, new calibration techniques, and highly precise sensors create a camera movement system that can endure the most challenging of shots while maintaining perfectly smooth footage.

# GETTING TO KNOW MōVI PRO

## SPECIFICATIONS

### DIMENSIONS

MōVI Pro	345 x 345 x 432mm (L*W*H)
Camera Cage	196 x 200 x 175mm (L*W*H)

### MECHANICAL

Pan Range of Motion	Unlimited
Roll Range of Motion	+60°
Tilt Range of Motion (Normal Mode)	+90° above horizontal to -165° below horizontal
Tilt Range of Motion (Inverted Mode)	+165° above horizontal to -90° below horizontal
Max Pan Rate	360°/s
Max Roll Rate	360°/s
Max Tilt Rate	360°/s
Weight	2.65kg
Max Payload	6.80kg
Max Operating Speed	100km/hr (dependent on payload)
Operating Temperatures	-20° to 50°C
Ingress Protection	IP52 (dust & water droplet protected)
Mounting System	Freely Toad In The Hole (TITH) Quick Release

### ELECTRONICS

Data Logging Rate	5, 10, and 25 Hz
Connections	Bluetooth Low Energy v4.2 and 2.4GHz Custom FHSS Radio
Motor Type	Direct-drive 3 phase Brushless
Data Storage	microSD
Port Types	<b>GCU ports:</b> COM1, 12V, COM 2 <b>TSU Ports:</b> LTC Timecode In/Out, EXP, CANbus + Battery Voltage, CAM, 12-14V CAM, 12V AUX, F,I,Z, USB Type C

# GCU AND TSU LAYOUTS

## GIMBAL CONTROL UNIT

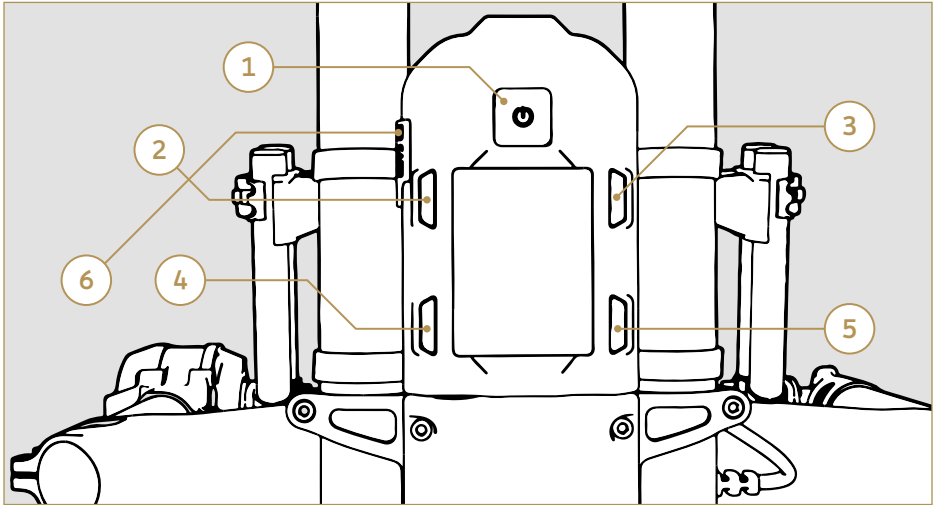

### GCU LAYOUT

- 1. Power Button
  - a. Push (ON)
  - b. Hold (OFF)
- 2. Back Button
- 3. Forward Button
- 4. Select Option (-)
- 5. Select Option (+)
- 6. microSD Card Slot

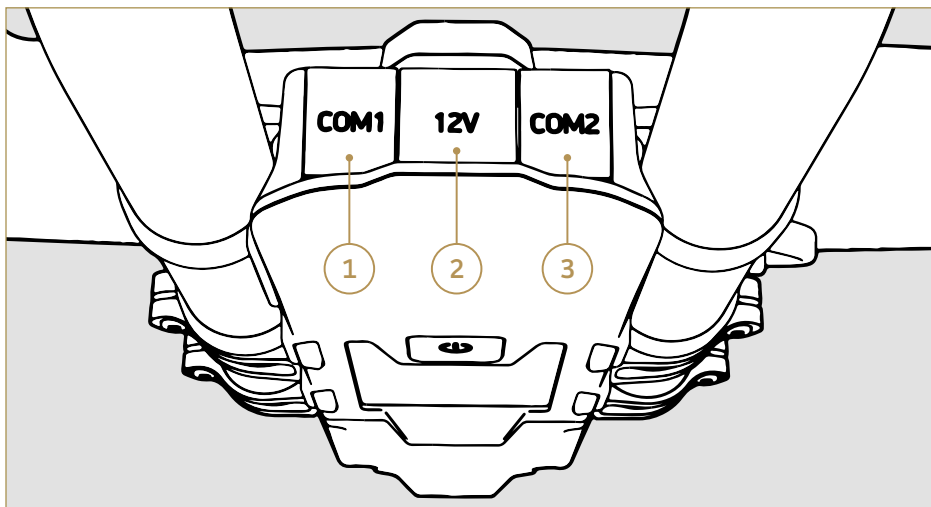

## GCU CONNECTOR LAYOUT

1. COM 1

2. 12V

3. COM 2

# TILT STAGE UNIT

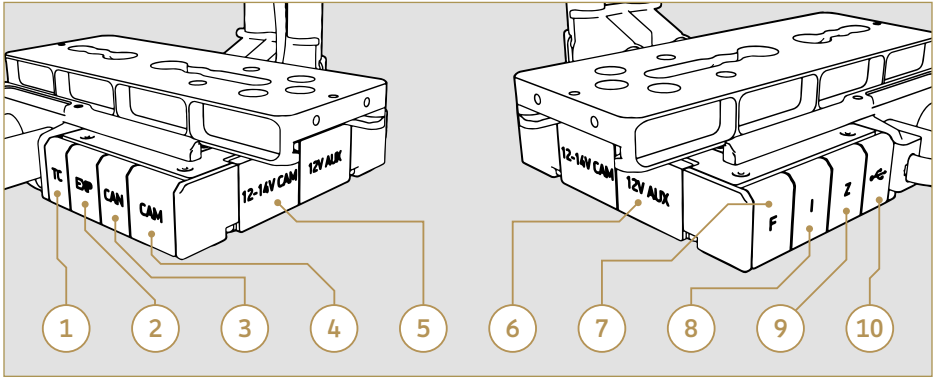

## TSU CONNECTOR LAYOUT

- 1. TC
- 2. EXP
- 3. CAN
- 4. CAM
- 5. 12-14V CAM
- 6. 12V AUX
- 7. Focus
- 8. Iris
- 9. Zoom
- 10. USB C DRP

# GIMBAL CONTROL UNIT CONNECTORS AND PINOUTS

All connector pinouts are shown looking into the function side of the connectors on the GCU and TSU, unless stated otherwise.

CONNECTOR: **COM 1**  
TYPE: **JST GH 6-PIN**

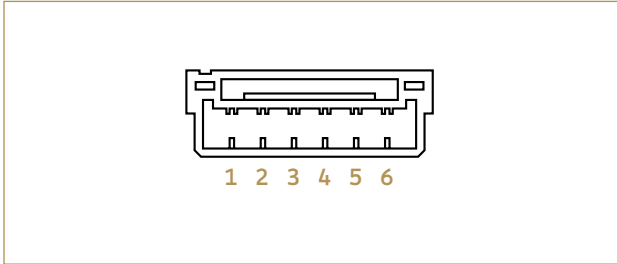

- 1. GND
- 2. +5V
- 3. UARTn\_TX
- 4. UARTn\_RX
- 5. UARTn\_CTS
- 6. UARTn\_RTS

CONNECTOR: **12V**  
TYPE: **FEMALE D-TAP**

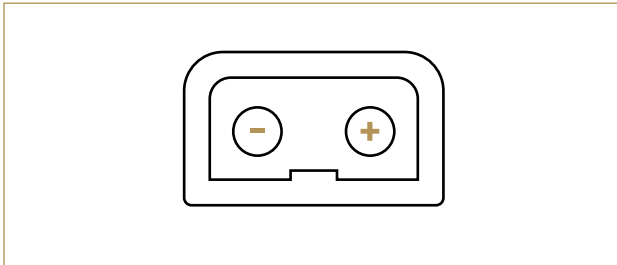

- 1. (+) 12V DTAP V+
- 2. (-) 12V DTAP GND

CONNECTOR: **COM 2**  
TYPE: **JST GH 6-PIN**

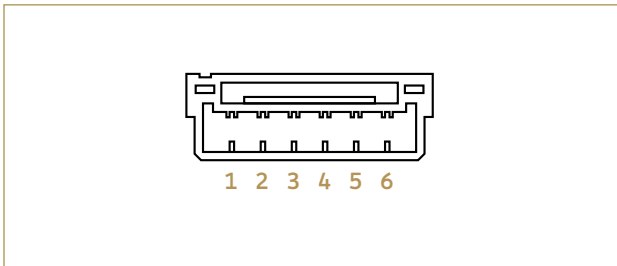

- 1. GND
- 2. +5V
- 3. UARTn\_TX
- 4. UARTn\_RX
- 5. UARTn\_CTS
- 6. UARTn\_RTS

# TILT STAGE UNIT CONNECTORS AND PINOUTS

All connector pinouts are shown looking into the function side of the connectors on the GCU and TSU, unless stated otherwise.

CONNECTOR: TC (LTC TIMECODE)  
TYPE: 3.5MM JACK

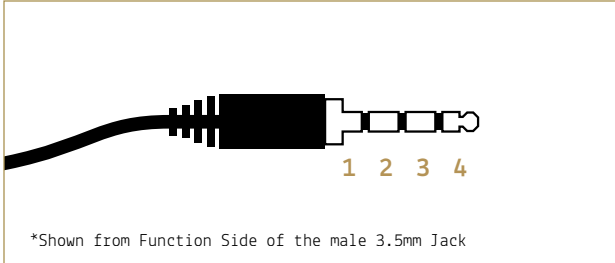

- 1. (Base, Mic) - LTC IN
- 2. (Ring, Gnd) - GND
- 3. (Ring, Right) - SYNC IN
- 4. (Tip, Left) - LTC OUT

CONNECTOR: EXP (EXPANSION)  
TYPE: JST ZPH 10 PIN

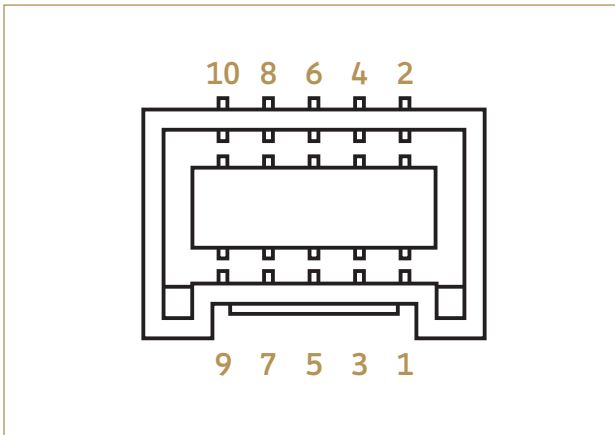

- 1. GND
- 2. +12V
- 3. GND
- 4. +5V
- 5. TxD1/Tx-
- 6. RXD1/Rx+
- 7. TxD2/Tx+
- 8. RXD2/Rx-
- 9. GPI/UART RX
- 10. GPO/UART TX



CONNECTOR: CAN (CANBUS)  
TYPE: MOLEX MICROFIT RA 4 PIN

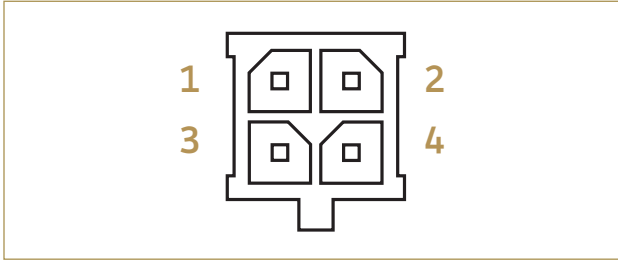

- 1. GND
- 2. +V Ba
- 3. CAN H
- 4. CAN L

CONNECTOR: CAM (CAMERA)  
TYPE: MOLEX MICROFIT RA 8 PIN

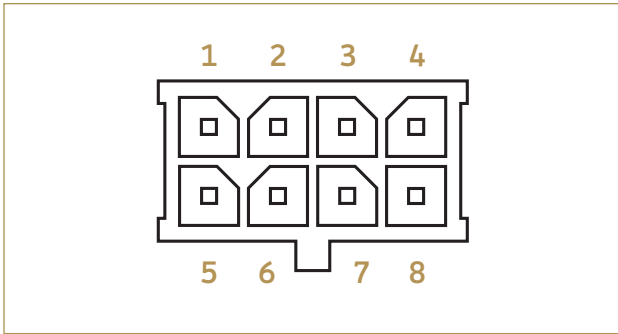

- 1. GND
- 2. +5V
- 3. RxD
- 4. TxD
- 5. LANC Power
- 6. LANC Signal
- 7. GPO/UART TX
- 8. GPI/UART RX

CONNECTOR: 12-14V CAM (CAMERA POWER)  
TYPE: FEMALE D-TAP

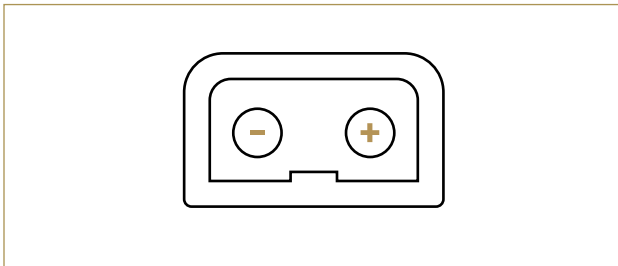

- 1. (+) 14V DTAP V+
- 2. (-) 14V DTAP GND

CONNECTOR: 12V (AUXILIARY POWER)  
TYPE: FEMALE D-TAP

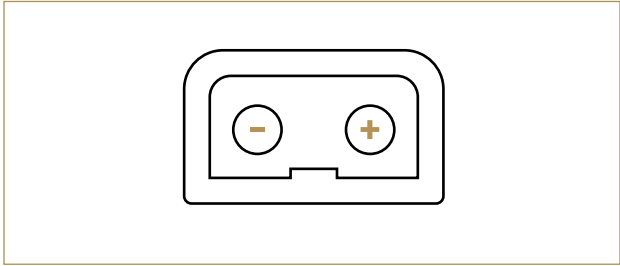

- 1. (+) 12V DTAP V+
- 2. (-) 12V DTAP GND

CONNECTOR: F (FOCUS MOTOR)  
TYPE: MOLEX MICROFIT RA 6 PIN

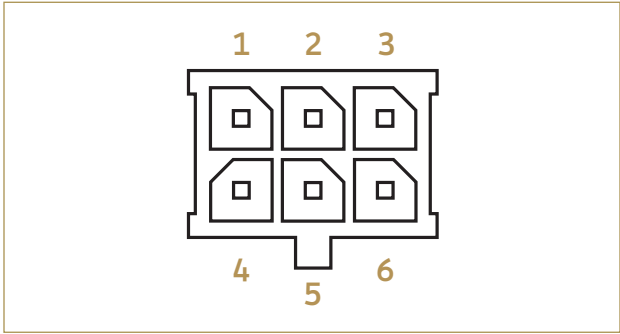

- 1. Motor A
- 2. Motor B
- 3. +5V
- 4. GND
- 5. Encoder A
- 6. Encoder B

CONNECTOR: I (IRIS MOTOR)  
TYPE: MOLEX MICROFIT RA 6 PIN

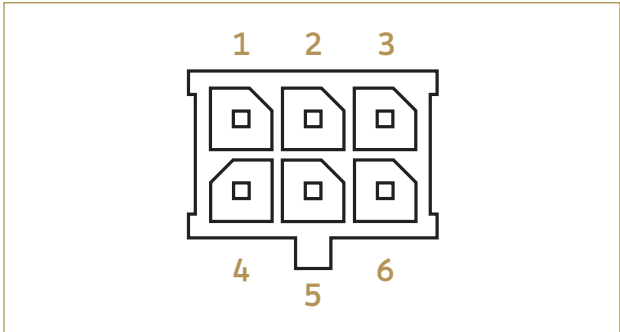

- 1. Motor A
- 2. Motor B
- 3. +5V
- 4. GND
- 5. Encoder A
- 6. Encoder B

CONNECTOR: Z (ZOOM MOTOR)  
TYPE: MOLEX MICROFIT RA 6 PIN

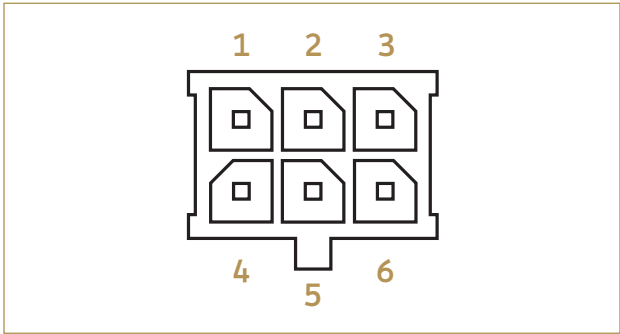

- 1. Motor A
- 2. Motor B
- 3. +5V
- 4. GND
- 5. Encoder A
- 6. Encoder B

CONNECTOR: USB PORT  
TYPE: USB TYPE C DRP (SOURCE AND SINK 5V)

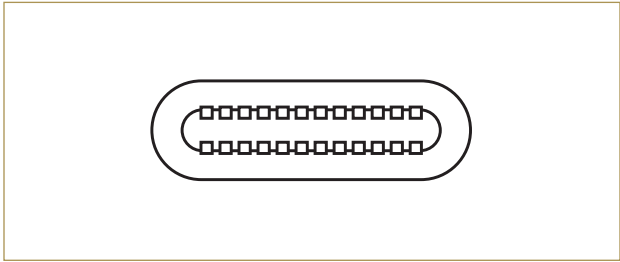

# SYSTEM DIAGRAMS

## MōVI PRO OVERVIEW

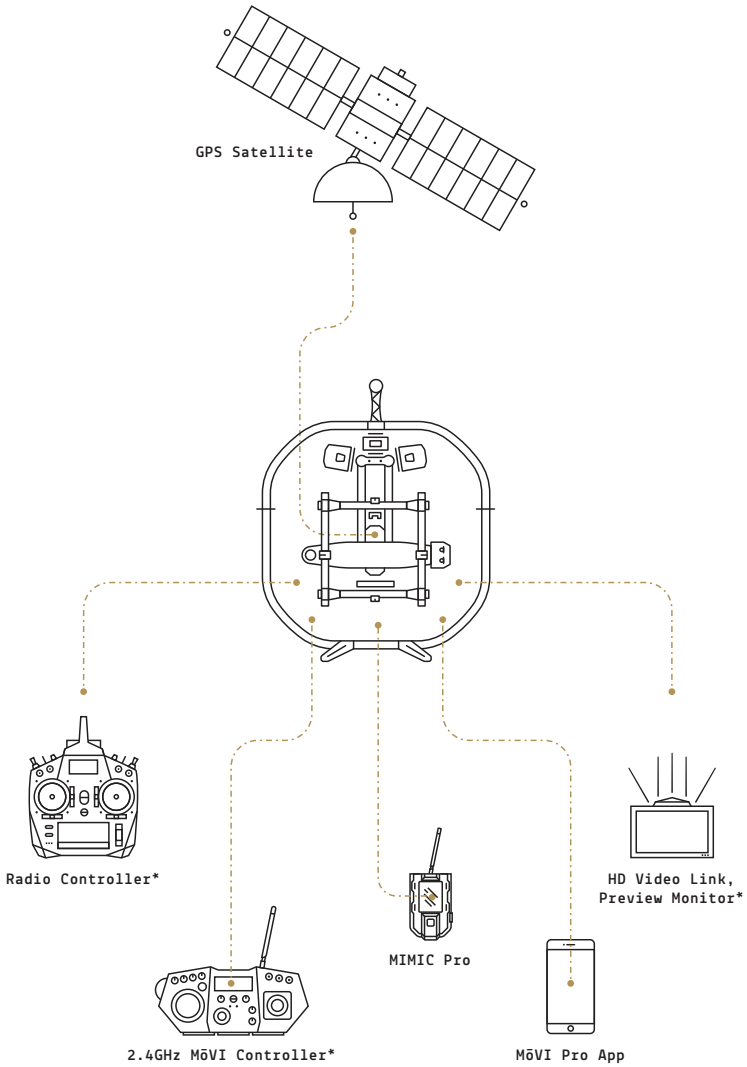

\*NOT INCLUDED

# MōVI PRO CONTROL PATHS

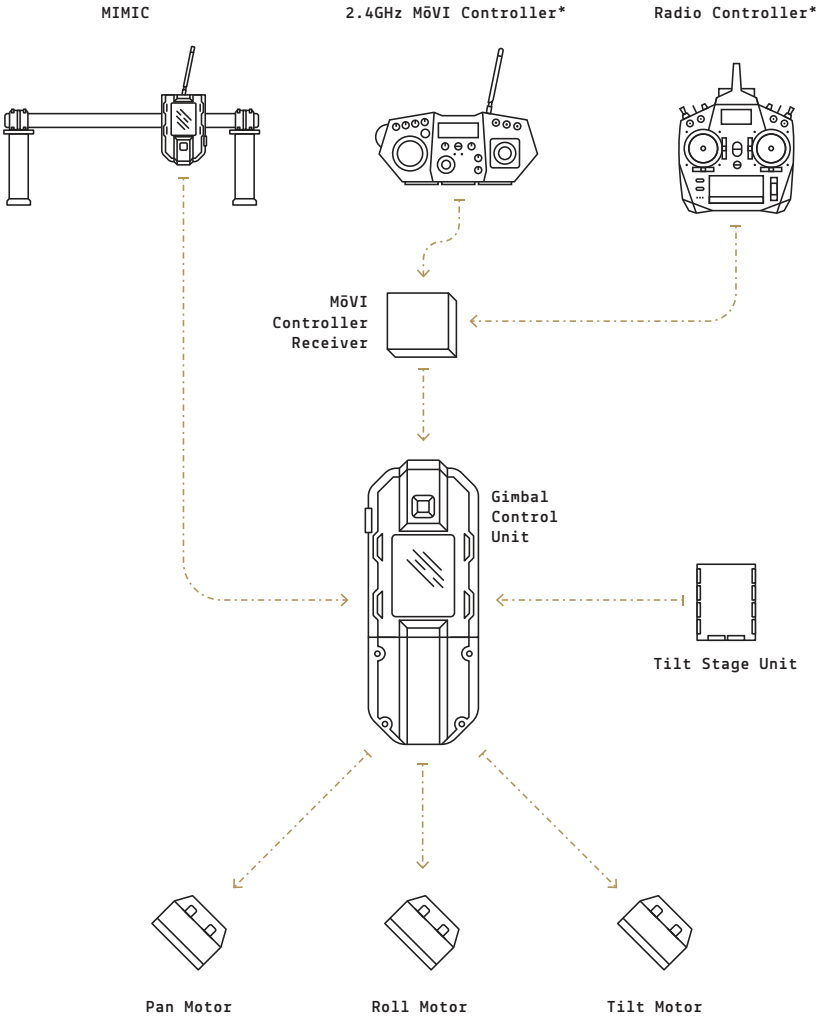

# MōVI PRO POWER SYSTEM

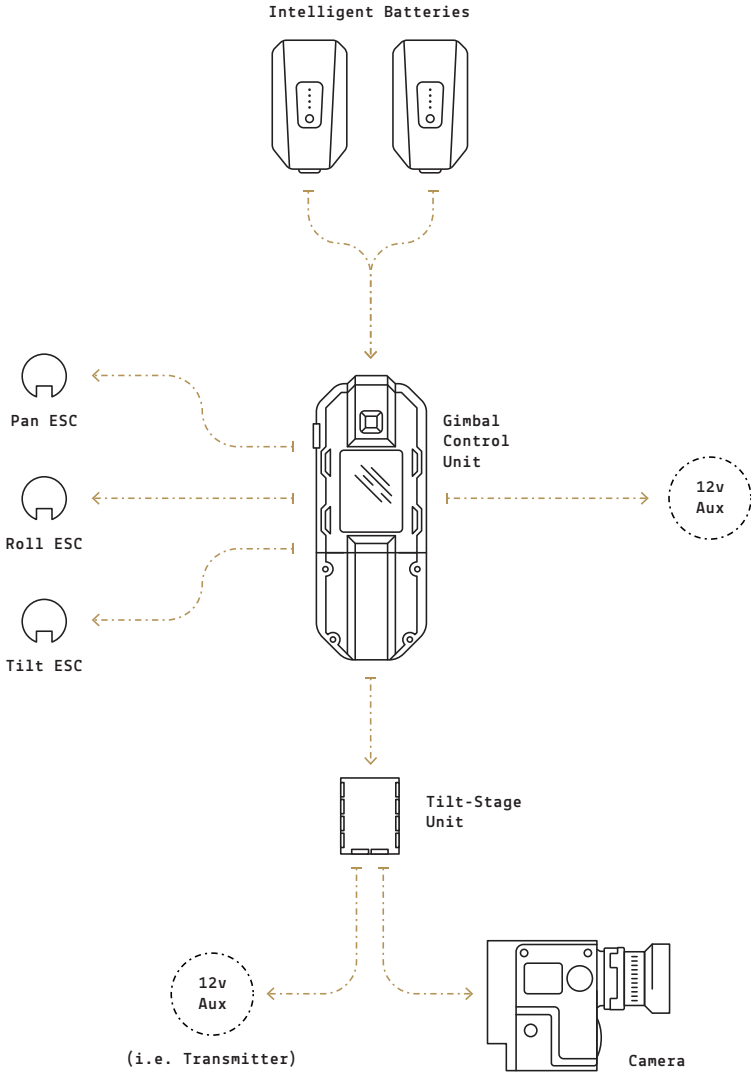

# MōVI PRO + MIMIC

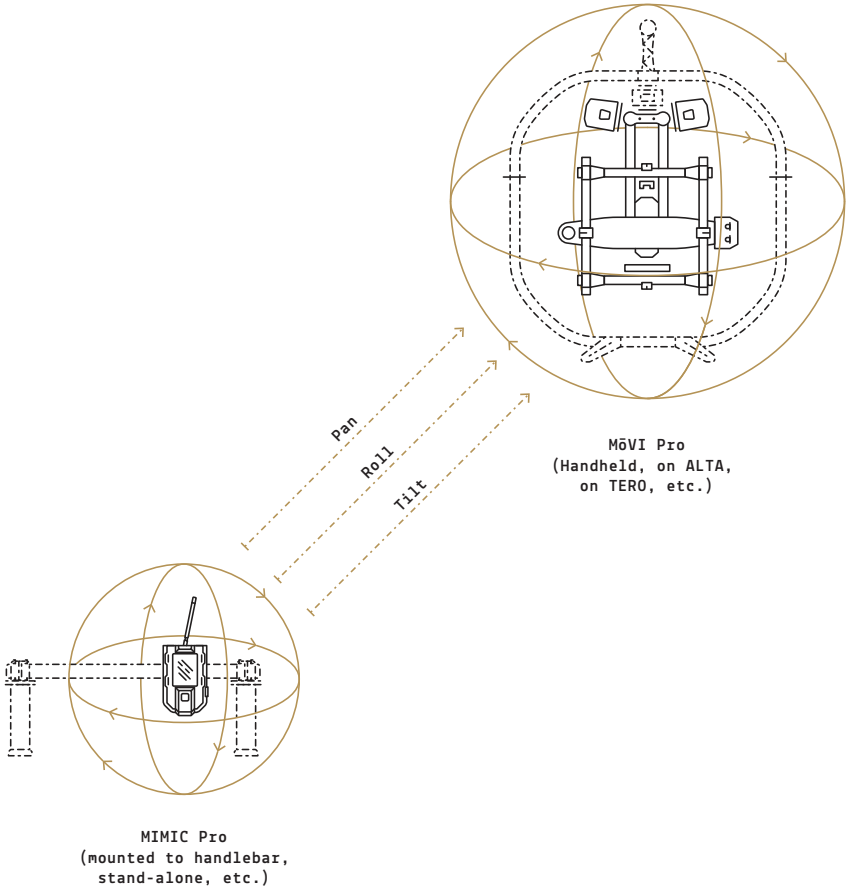

# MōVI PRO APP

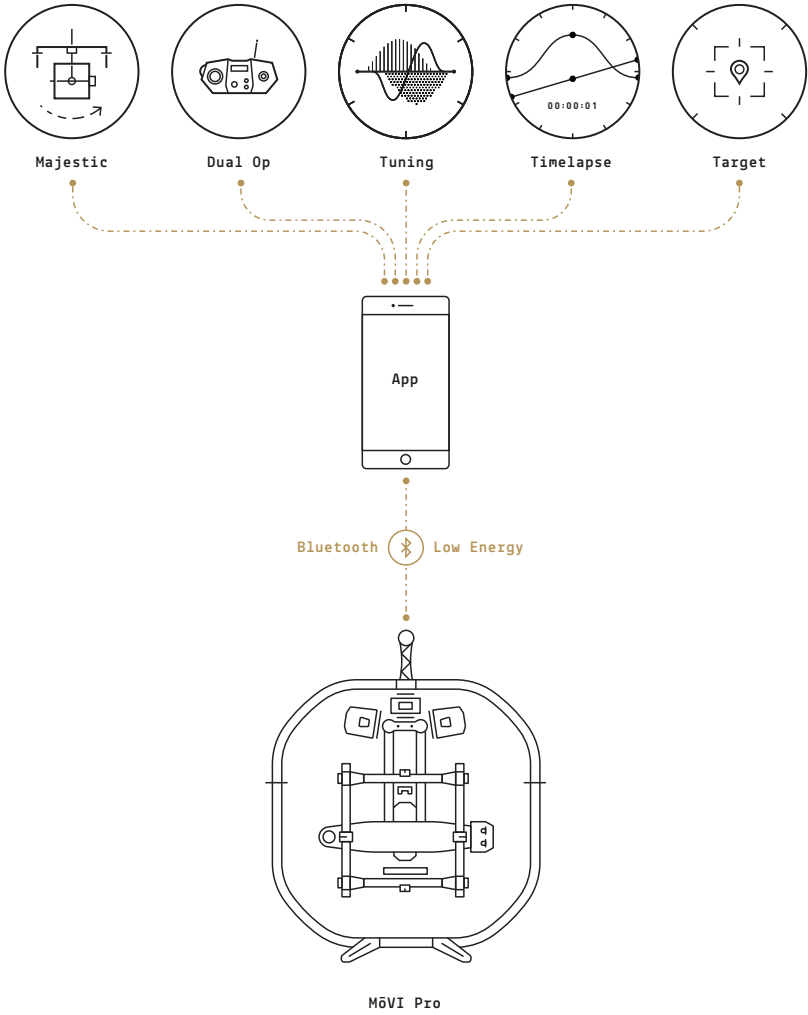



# MōVI PRO KIT

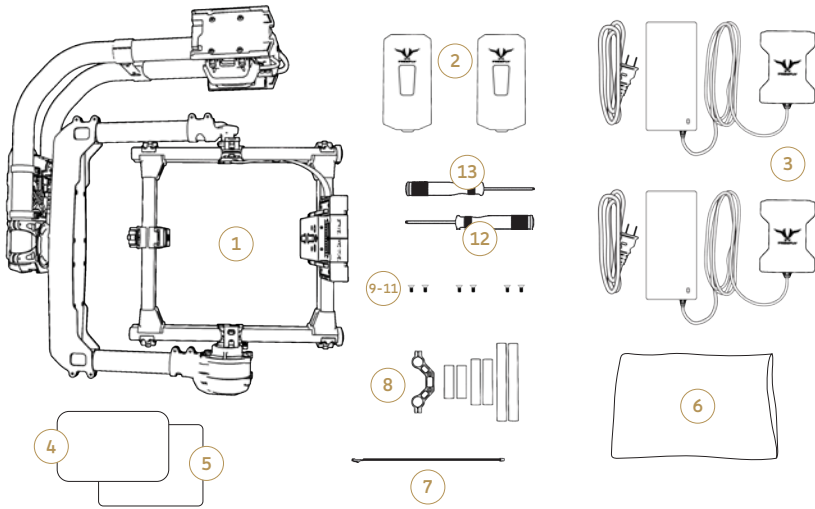

## INCLUDED WITH THE MōVI PRO

- |                                     |                             |
|-------------------------------------|-----------------------------|
| 1. MōVI Pro                         | 8. MōVI Rod Mount Adapter   |
| 2. [2] MōVI Pro Battery Packs 1.8Ah | 9. [2] Bolt 3/8 -16 x 5/8"  |
| 3. [2] MōVI Pro Battery Charger     | 10. [2] Bolt 1/4 -20 x 1/2" |
| 4. MōVI Pro QuickStart Card         | 11. [2] Bolt 1/4 -20 x 3/8" |
| 5. Product Card                     | 12. 2.0mm Hex Driver        |
| 6. MōVI Pro Accessory Bag           | 13. 2.5mm Hex Driver        |
| 7. uART to FRX Cable                |                             |

## \*OPTIONAL ACCESSORIES

- |                         |                                       |
|-------------------------|---------------------------------------|
| 14. MōVI Ring Pro       | 19. MōVI Pro Landing Gear             |
| 15. MōVI Classic Handle | 20. MōVI Low Profile Handle           |
| 16. MIMIC               | 21. MōVI Ninja Star Adapter Plate     |
| 17. MōVI Pro Case       | 22. MōVI Pro Aerial Case              |
| 18. MōVI Dock           | 23. MōVI Pro Pop-n-Lock Quick Release |

\*Optional accessories are available for purchase separately

A professional camera rig is shown in a dark, nighttime setting. The rig is mounted on a tripod and includes a camera, a microphone, and various accessories. The background is filled with out-of-focus city lights, creating a bokeh effect. The overall mood is professional and cinematic.

SETTING UP  
MōVI PRO

# MōVI PRO SETUP AT A GLANCE

---

Charging Batteries	39
Building the Basic Camera Package	41
Building the Cinematographic Camera Package	43
Mounting a RED Camera	43
Mounting an ARRI Camera	44
Mounting a Sony F-series Camera	45
Mounting a Canon C-series Camera	46
Mounting a Black Magic Cinema Camera	47
Mounting the Camera Package	53
Wiring Guide	56
Balancing the MōVI Pro	59
Tuning the MōVI Pro	63
Updating the MōVI Pro	67
MōVI Pro + Freely Ecosystem	68

When your MōVI Pro arrives, it will be securely packed along with all of the items in the MōVI Pro base package. This section will take you through each of the steps needed to set up the MōVI Pro and prepare it for use.

# TOAD IN THE HOLE QUICK RELEASE

TITH Quick Release is a sleek, lightweight, low-profile quick release unit, which provides an easy mount and release solution for all your Freelyfly products.

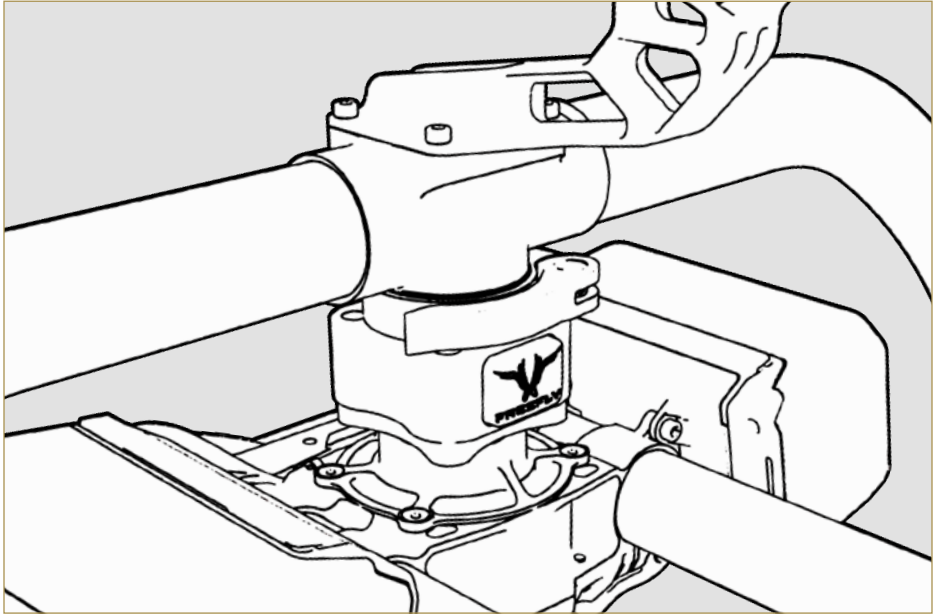

## MOUNTING PROCEDURE

1. Open the lever on the female part of the TITH.

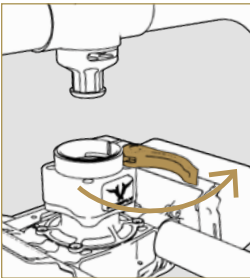

2. Align the male and female parts of the TITH and press them together until you feel the parts engage and hear a click.

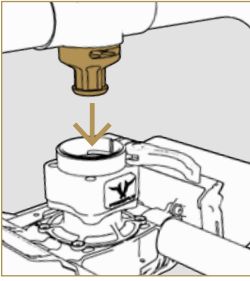

3. Hold the MōVI Pro securely; check to see if the TITH engaged correctly and then rotate the TITH to your desired orientation.
4. Continue to hold the MōVI Pro securely and close the TITH's lever while making sure that none of the release buttons are pressed. This concludes the TITH mounting procedure.

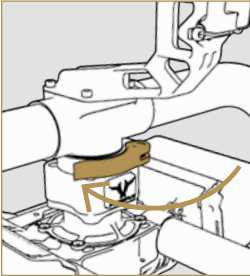

### CAUTION

Always check to see whether the TITH has engaged correctly and make sure that none of the release buttons are pushed while the TITH lever is being closed. Closing the lever on a TITH that has been incorrectly mounted can result in the sudden release of the gimbal which can cause damage to the MōVI Pro and any equipment mounted to it.

## RELEASE PROCEDURE

1. Hold the MōVI Pro securely in one hand so the gimbal does not fall during the release process.
2. While supporting the MōVI Pro, open the lever and press the two release buttons on the TITH simultaneously.

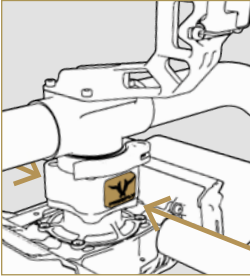

3. The male and female parts of the TITH have now released and can now be pulled apart.

# CHARGING BATTERIES

---

Your MōVI Pro comes with two MōVI Pro Battery Packs and two MōVI Pro Battery Pack Chargers. Follow the charging procedure below to maintain a safe charging environment.

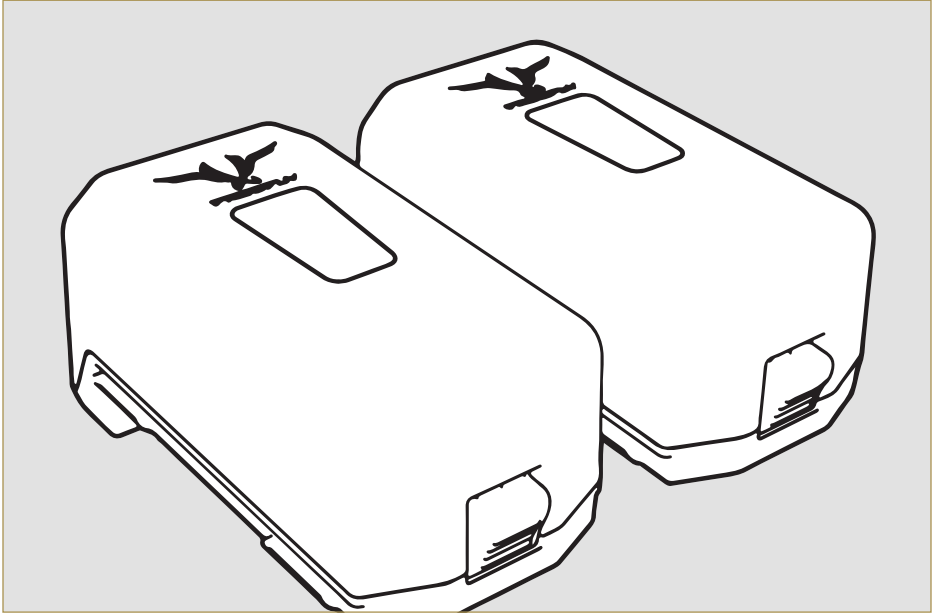

## MōVI PRO BATTERY PACK CHARGING PROCEDURE

1. Insert the AC power cord into AC power adapter and plug the power cord into a 120 VAC wall socket (US).
2. The AC power adapter's LED will turn a solid GREEN. This means the MōVI Pro Battery Pack charger is ready to charge.

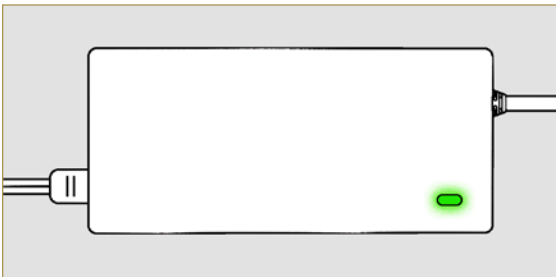

- Slide the Charging Dock along the underside of the battery until the battery's connector is completely engaged with the Charging Dock.

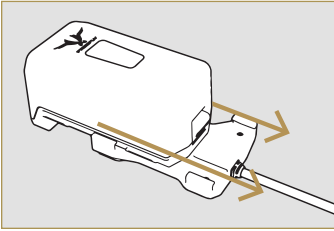

- The AC power adapter's LED will turn RED to inform you that the battery is charging.

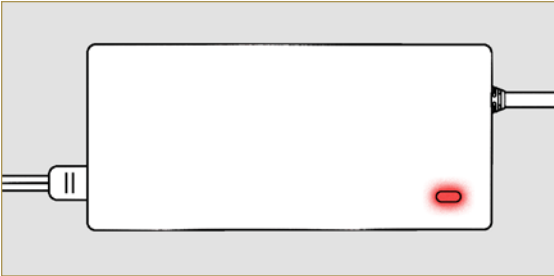

- When the AC power adapter's LED returns to GREEN, your battery is fully charged. Press the power button on the battery to check the power level, and disconnect the battery from the charger.



### CAUTION

For all warnings concerning the batteries and chargers please refer to the Warning section on page 9.



### WARNING

Only charge the MōVI Pro Battery Pack with a Freely Systems MōVI Pro Battery Pack Charger. The use of 3rd party chargers is dangerous and may result in damage to the batteries, cause severe personal injury, or start a fire.



# SETTING UP YOUR CAMERA PACKAGE

---

It is important that you fully build your camera package prior to balancing it on the MōVI Pro. Adding accessories such as focus motors, receivers, batteries, etc. to your MōVI Pro after balancing will put the setup out of balance and require you to rebalance the system. The MōVI Pro uses a custom lightweight camera rail to allow you to easily install and remove your camera package. The camera rail is also used to adjust the balance of the camera package.

## BASIC SETUP

These instructions will teach you how to quickly set up most DSLR and Mirrorless cameras with the MōVI Pro. Some of the items in these instructions are not part of the MōVI Pro Kit.

### CAMERA+LENS

1. Mount your preferred camera lens onto your camera by following the specific lens mounting procedure required by the camera.

## MOUNTING THE CAMERA RAIL

### Items Needed

- » Camera Package
- » Camera Rail
- » [2] 1/4 -20 bolt\*
- » [2] 3/8 -16 bolt\*
- » 5/32" Hex Driver\*
- » 7/32" Hex Driver\*

\*Depending on camera package setup

1. Use the 1/4 -20 bolts to mount the camera to the camera rail. The camera rail also accepts a 3/8 -16 bolts for larger cameras.



For cameras without FIZ motors, mount the camera on the rail such that the camera and lens package's center of gravity is as close to the center of the rail as possible. This will be useful during the balancing process.

## HOT SHOE AND TOP RAIL

### Items Needed

- » Camera Package
  - » Top Rail
  - » Hot Shoe Adapter
  - » (2) M3 Screw
  - » 2.5mm Hex Driver
1. Loosen the Hot Shoe Adapter located on one end of the top rail and insert it into the Hot Shoe on your camera. Once inserted, tighten the M3 screws and check that the top rail is secure.

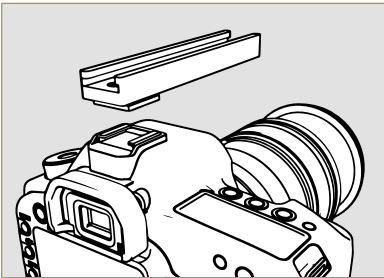

2. Continue to page 53 for instructions on how to mount, balance, and tune your MōVI Pro.



Some cameras do not have a hot shoe adapter; in these cases, the top rail will mount directly to the camera without the use of the Hot Shoe Adapter.

# ADVANCED SETUP

These instructions will show you how to set up your MōVI Pro with popular cinematographic cameras, FIZ controls, a video transmitter, and a monitor. Some of the items in these instructions are not part of the MōVI Pro Kit.

## SETTING UP CAMERA AND LENS

### Items Needed

- » Camera
- » Lens Gears\*\*
- » Lens

\*Any setup using a FIZ system will also require the use of a MōVI Controller, which is not part of the MōVI Pro Kit but is available for purchase separately.

\*\*These items are not included with the MōVI Pro.

1. If necessary, mount lens gears over the focus, zoom, or iris rings of the lens.
2. Mount the camera lens onto the camera by following the specific lens mounting procedure required by the camera.

## MOUNTING RED CAMERAS TO THE CAMERA RAIL

### Items Needed

- » Camera Package\*
- » Camera Rail
- » Top Rail
- » ¼-20 Bolt
- » [2] 3/8-16 Bolt
- » 5/32" Hex Driver\*
- » 7/32" Hex Driver\*

\*These items are not included with the MōVI Pro.

1. Locate the 3/8-16 bolts, the camera rail, and the 7/32" hex driver from the MōVI Pro package.
2. RED cameras can be mounted using the two 3/8-16 bolt locations on the camera rail. See the diagram for suggested camera rail placement.

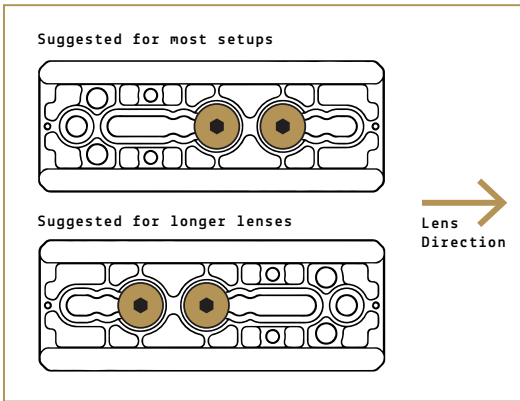

3. Use the 1/4 -20 bolt and the 5/32 hex driver to attach the top rail to the top of the camera. The rail should be mounted perpendicular to the front of the camera.
4. Proceed to page 48 for instructions on how to mount the FIZ motor to the camera package.

## MOUNTING ARRI CAMERAS TO THE CAMERA RAIL

### Items Needed

- » Camera Package\*
- » Camera Rail
- » Top Rail
- » V-lock Adapter Kit for ALEXA Mini\*
- » [3] 1/4 -20 Bolt
- » [8] M4 Screw 4.4mm\*
- » 5/32" Hex Driver\*
- » 3mm Hex Driver

\*These items are not included with the MōVI Pro.

1. Attach the aluminum mounting plates from the V-Lock Adapter Kit to the top and bottom of the ARRI Camera using all eight M4 screws. Make sure that the adapter plates are firmly secured and there is no play.
2. Align the camera rail so the two 1/4 -20 bolt holes on the lower aluminum mounting plates match an ARRI style bolt pattern on the camera rail. Insert and tighten the bolts until the camera is secured and has no play. See the diagram for suggested camera rail placement.

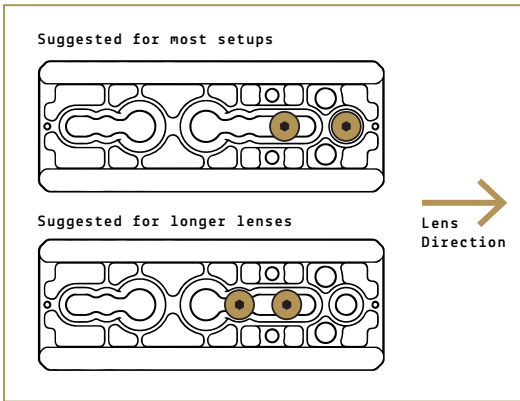

3. Use the 1/4 -20 bolt and the 5/32 hex driver to attach the top rail to the upper aluminum mounting plates. The rail should be mounted perpendicular to the front of the camera.
4. Proceed to page 48 or instructions on how to mount the FIZ motor to the camera package.

## MOUNTING SONY CAMERAS TO THE CAMERA RAIL

### Items Needed

- » Camera Package\*
- » Camera Rail
- » Top Rail
- » 1/4 -20 Bolt
- » [2] 3/8-16 Bolt
- » 5/32" Hex Driver\*
- » 7/32" Hex Driver\*

\*These items are not included with the MōVI Pro.

1. Locate the 3/8-16 bolts, the 7/32" hex driver, and the camera rail from the MōVI Pro package.
2. Align the camera rail with the two 3/8-16 bolt holes on the bottom of the Sony camera. Insert and tighten the bolts until the camera is secured and has no play. See the diagram for suggested camera rail placement.

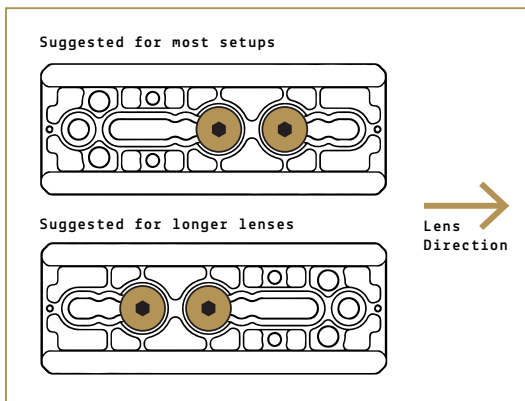

3. Remove the Sony's handle before mounting the top rail.
4. Use a  $\frac{1}{4}$  -20 bolt and the 5/32 hex driver to attach the top rail to the top of the camera. The rail should be mounted perpendicular to the front of the camera.
5. Proceed to page 48 for instructions on how to mount the FIZ motor to the camera package.

## MOUNTING CANON C SERIES CAMERAS TO THE CAMERA RAIL

### Items Needed

- » Camera Package\*
- » Camera Rail
- » Top Rail
- » Hot shoe Adapter
- » [2] M3x6 Screw
- »  $\frac{1}{4}$  -20 Bolt
- » 3/8-16 Bolt
- » 5/32" Hex Driver\*
- » 7/32" Hex Driver\*
- » 2.5mm Hex Driver

\*These items are not included with the MōVI Pro.

1. Locate one  $\frac{1}{4}$ -20, one 3/8-16 bolt, and the camera rail from the MōVI Pro kit.
2. Align the camera rail so the  $\frac{1}{4}$ -20 and 3/8-16 bolt holes on the bottom of the Canon camera match the Canon camera bolt pattern on the camera rail. Insert and tighten the bolts using the hex drivers until the camera is secured and has no play. See the diagram for suggested camera rail placement.
3. Insert the hot shoe adapter into the hot shoe of the Canon camera and attach the top camera rail to the hot shoe adapter using two M3x6 flat head screws.
4. Proceed to page 48 for instructions on how to mount the FIZ motor to the camera package.

# MOUNTING BLACK MAGIC CINEMA CAMERA TO THE CAMERA RAIL

## Items Needed

- » Camera Package\*
- » Camera Rail
- » Top Rail
- » [2] ¼ -20 Bolt
- » 5/32" Hex Driver\*

\*These items are not included with the MōVI Pro.

1. Locate the ¼ -20 bolts, the 5/32" hex driver, and the camera rail from the MōVI Pro package.
2. Align the camera rail to the ¼ -20 bolt hole on the bottom of the Black Magic camera. Insert and tighten the bolts until the camera is secured and has no play. See the diagram for suggested camera rail placement.

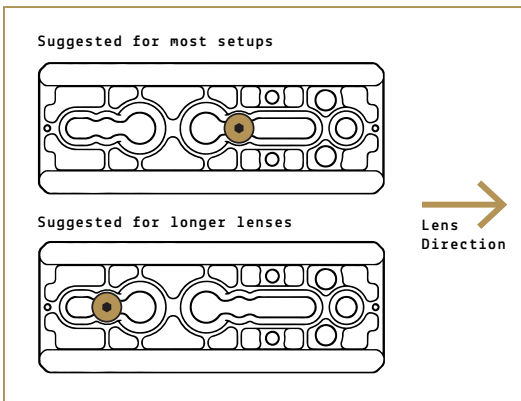

3. Use a ¼ -20 bolt and the 5/32 hex driver to attach the top rail to the top of the camera. The rail should be mounted perpendicular to the front of the camera.
4. Proceed to page 48 for instructions on how to mount the FIZ motor to the camera package.

# SETTING UP FIZ

## Items Needed

- » Camera Package\*
- » MōVI Rod Mount
- » FIZ Motors\*
- » [2] M3 x 8
- » 2.5mm Hex Driver

\*These items are not included with the MōVI Pro.

1. Attach the MōVI Rod Mount to the front of the camera rail with two M3 screws. The rod mount can be attached with the arms pointing up or down. The mount orientation will depend on the length of the FIZ motors and the diameter of the lens on the camera.

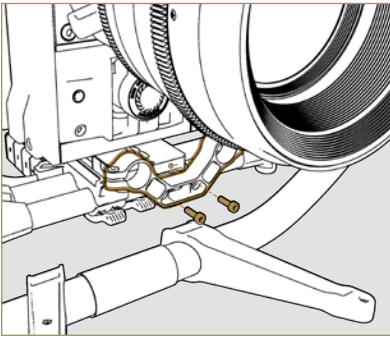

2. Measure the distance from the front of the camera rail to the farthest lens gear and choose the carbon fiber rod that is at least as long as this distance. Some camera packages will require two carbon fiber rods so FIZ motors can be mounted on both sides of the MōVI Rod Mount.



3. Take the MōVI Rod Mount and install the appropriate length carbon fiber rod into one of the ring clamps on the rod mount. Once the carbon fiber rod is flush with the back of the rod mount, tighten the M3 screw to secure the rod in place.

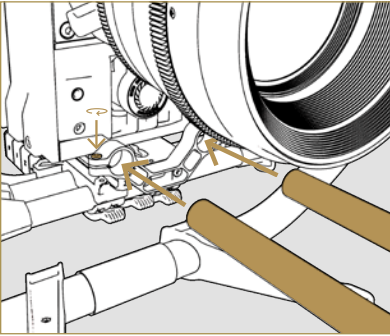

4. Mount and position your FIZ motors on the carbon rods so the gears interlock fully with their respective lens gears. Tighten the FIZ motor onto the carbon rod.

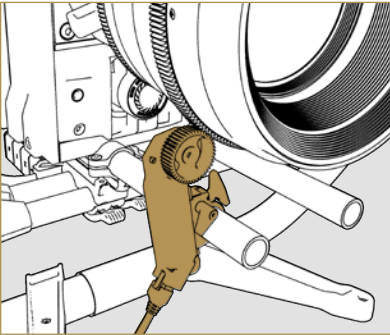

# ATTACHING A TRANSMITTER

## Items Needed

- » MōVI Pro Gimbal
- » Video Transmitter\*
- » MōVI Pro Pop-n-Lock Quick Release\*
- » 1/4-20 Bolt
- » 5/32 Hex Driver\*

\*These items are not included with the MōVI Pro.

1. Open the clamp on the Pop-n-Lock and attach it to one of the suggested transmitter mounting locations. Make sure the mount faces away from the camera and the clamp is closed after the Pop-n-Lock is mounted.

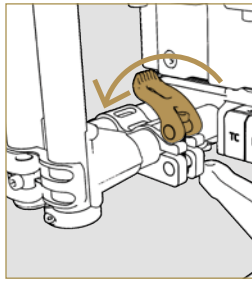
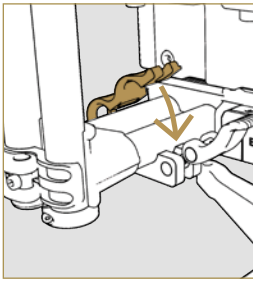

2. Attach the transmitter to the Pop-n-Lock plate with a 1/4 -20 bolt.

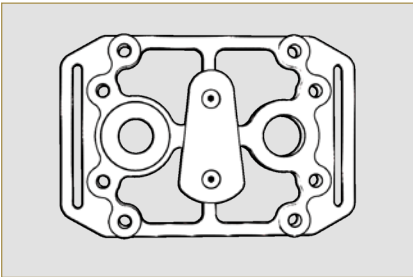

3. Slide the plate into the Pop-n-Lock base to mount the transmitter to the MōVI Pro.

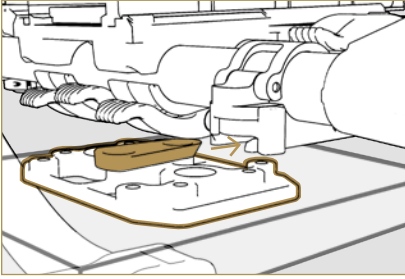

4. Rotate the latch on the Pop-n-Lock to secure the transmitter.

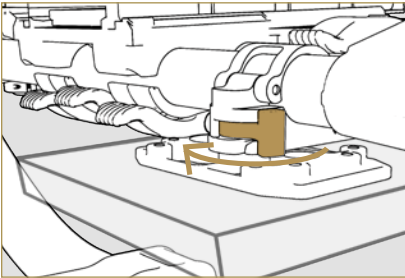

# MOUNTING A MONITOR

## Items Needed

- » MōVI Ring Pro\*
- » Monitor\*
- » Monitor Mount\*

\*These items are not included with the MōVI Pro.

1. Use the ¼-20 bolt on the MōVI Ring Pro handle to mount your preferred monitor or monitor mount.

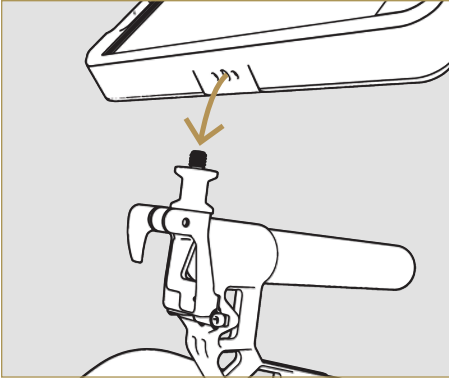

# MOUNTING THE CAMERA PACKAGE

## Items Needed

- » MōVI Pro Gimbal
- » Camera Package\*
- » MōVI Ring Pro\*

1. Open the side clamps on the top horizontal crossbar and move the bar up so the camera has room to fit in the cage.

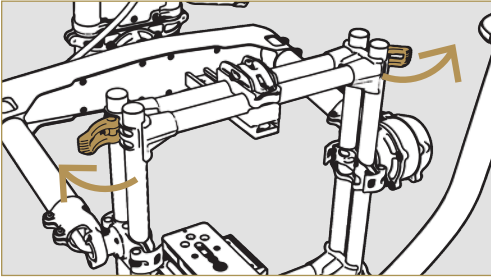

2. Open the top and bottom camera rail toggle clamps, and rotate the top toggle 90 degrees counterclockwise.

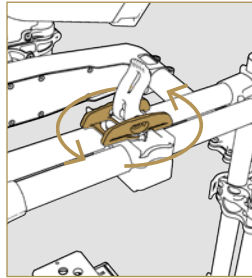
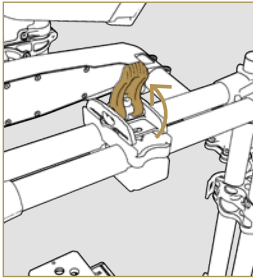

3. Position the camera package so the camera rail and dovetail are aligned, and then slide the camera package onto the dovetail.

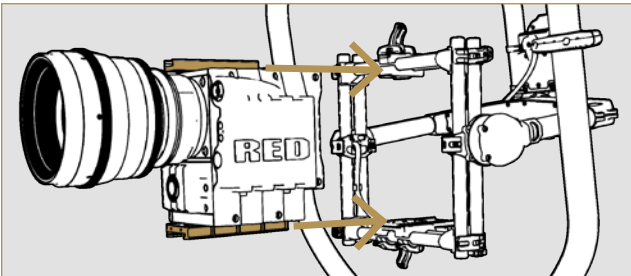

4. Close the bottom camera rail toggle clamp. Align the top camera rail with the toggle, and lower the upper crossbar.
5. Make sure the top camera rail is engaged with the locking mechanism, and twist the top toggle 90 degrees clockwise and close the clamp.
6. The camera package is now mounted. If you are using a monitor or intervalometer, connect the wires to the appropriate ports on the camera and make sure the MōVI Pro's movement is not restricted.

# BATTERY INSTALLATION AND RED, ARRI, SONY, CANON WIRING

MōVI Pro has a integrated DC camera power supply, FIZ controller, and the capability to hot swap batteries. These features will reduce the wire clutter around the camera and allow continuous shooting even during battery swaps.

## BATTERY INSTALLATION AND HOT SWAPPING

1. Take a MōVI Pro Battery Pack and slide it along the battery tray. Make sure all four rails engage and the battery slides smoothly along the tray.

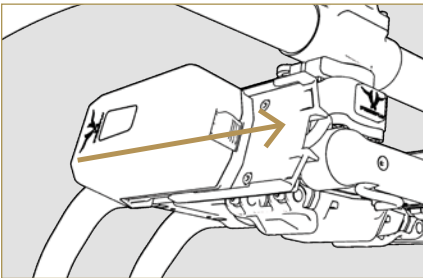

2. Push the battery until the connectors are fully engaged and the battery locks into place.
3. To remove the battery, lift up on the battery latch and slide the battery out of the tray.

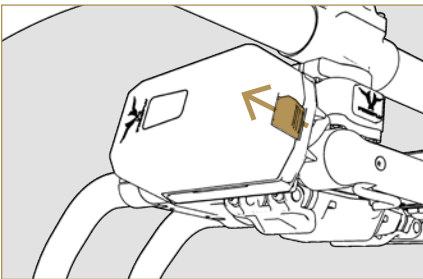

4. To hot swap MōVI Pro batteries, simply remove and replace the batteries one at a time.



**CAUTION**

If you are using the MōVI Pro to power the camera, a loss of battery power will result in a sudden loss of power to the camera. This can damage the camera and result in a loss of data. Monitor the battery levels using the GCU display and swap the batteries out as needed.

# FREELY CABLE GUIDE

Use this cable guide to assist in the wiring of some popular cameras. For information on the MōVI Pro's Connectors and Pinouts see page 23. To order Freelyfly cables please visit the Freelyfly Online Store at <http://store.freelyflysystems.com>.

FREELY CABLES	CONNECTOR SIDE A	CONNECTOR SIDE B
Freelyfly ARRI ALEXA Mini Power Cable	DTAP	LEMO 2B 8 pin
Freelyfly ARRI Remote Start Cable	MicroFit 8 Pin Double Row	LEMO 1B 7 Pin
Freelyfly Connex Air Unit Control Cable	GH 6 pin	GHR-05V-S
Freelyfly Connex Ground Unit Control Cable	LEMO 1B 7 Pin	2.5mm Headphone jack
Freelyfly Connex Power Cable	DTAP	GHR-04V-S
Freelyfly FRX Control Cable	GH 6 pin	ZH 5 pin
Freelyfly Futaba Radio Control Cable	GH 6 pin	JR Universal Connector
Freelyfly LANC Control Cable	MicroFit 8 Pin Double Row	2.5MM Stereo Jack
Freelyfly Lens Motor Cable - Right Angle	MicroFit 6 Pin Double Row	LEMO 1B 7 Pin
Freelyfly Lens Motor Cable - Straight	MicroFit 6 Pin Double Row	LEMO 1B 7 Pin
Freelyfly RED Power Cable	DTAP	LEMO 1B 6 Pin
Freelyfly RED Remote Start Cable	MicroFit 8 Pin Double Row	LEMO 00 4 Pin
Freelyfly RED REDLink Command Protocol Cable	MicroFit 8 Pin Double Row	LEMO 00 4 Pin
Freelyfly Spektrum Radio Control Cable	GH 6 pin	ZHR-3

## RED EPIC AND SCARLET

CABLE PURPOSE	WHAT DOES IT CONNECT	PORT NAMES	CABLE
Camera Power	Gimbal → Camera	12-14V CAM → DC-IN	Freelyfly RED Power Cable
Camera Control	Gimbal → Camera	CAM → CTRL	Freelyfly RED REDLink Command Protocol Cable
FIZ Motor Power and Control	Gimbal → FIZ Motor	F,I,Z → FIZ Motor Connector	Freelyfly Lens Motor Cable
Transmitter Power	Gimbal → Transmitter	12V AUX → DC IN	Freelyfly Connex Power Cable DTap → LEMO 0B 2-Pin (Paralinx Tomahawk)
Video Signal	Camera → Transmitter	HD-SDI → HD-SDI Or HDMI → HDMI IN	BNC → BNC HDMI → HDMI



## ARRI ALEXA MINI

CABLE PURPOSE	WHAT DOES IT CONNECT	PORT NAMES	CABLE
Camera Power	Gimbal → Camera	12-14V CAM → DC-IN	Freely ARRI ALEXA Mini Power Cable
Camera Control	Gimbal → Camera	CAM → CTRL	Freely ARRI Remote Start Cable
FIZ Motor Power and Control	Gimbal → FIZ Motor	F,I,Z → FIZ Motor Connector	Freely Lens Motor Cable
Transmitter Power	Gimbal → Transmitter	12V AUX → DC IN	Freely Connex Power Cable DTap → LEMO 0B 2-Pin (Paralinx Tomahawk)
Video Signal	Camera → Transmitter	HD-SDI → HD-SDI	BNC → BNC

## SONY F-SERIES (F5, F55)

CABLE PURPOSE	WHAT DOES IT CONNECT	PORT NAMES	CABLE
Camera Power	Gimbal → Camera	12-14V CAM → DC-IN	DTap → CCDD-X2 4 Pin
Camera Control	Gimbal → Camera	CAM → LANC	Freely LANC Control Cable
FIZ Motor Power and Control	Gimbal → FIZ Motor	F,I,Z → FIZ Motor Connector	Freely Lens Motor Cable
Transmitter Power	Gimbal → Transmitter	12V AUX → DC IN	Freely Connex Power Cable DTap → LEMO 0B 2-Pin (Paralinx Tomahawk)
Video Signal	Camera → Transmitter	SDI-OUT (1-4) → HD-SDI Or HDMI OUT → HDMI	BNC → BNC HDMI → HDMI

## CANON C-SERIES

CABLE PURPOSE	WHAT DOES IT CONNECT	PORT NAMES	CABLE
Camera Power	Gimbal → Camera	12-14V CAM → DC-IN	DTap → Canon DC Plug
Camera Control	Gimbal → Camera	CAM → Remote	Freely LANC Control Cable
FIZ Motor Power and Control	Gimbal → FIZ Motor	F,I,Z → FIZ Motor Connector	Freely Lens Motor Cable
Transmitter Power	Gimbal → Transmitter	12V AUX → DC IN	Freely Connex Power Cable DTap → LEMO 0B 2-Pin (Paralinx Tomahawk)
Video Signal	Camera → Transmitter	HDMI OUT → HDMI	HDMI → HDMI* <i>*May depend on C-Series camera</i>

# BLACK MAGIC CINEMA CAMERA

CABLE PURPOSE	WHAT DOES IT CONNECT	PORT NAMES	CABLE
Camera Power	Gimbal → Camera	12-14V CAM → DC-IN	DTap → Black Magic DC Plug
Camera Control	Gimbal → Camera	CAM → Remote	Freefly LANC Control Cable
FIZ Motor Power and Control	Gimbal → FIZ Motor	F,I,Z → FIZ Motor Connector	Freefly Lens Motor Cable
Transmitter Power	Gimbal → Transmitter	12V AUX → DC IN	Freefly Connex Power Cable DTap → LEMO 0B 2-Pin (Paralinx Tomahawk)
Video Signal	Camera → Transmitter	SDI OUT → SDI	BNC → BNC



## NOTE

Always use lightweight Freefly brand cables for best results.



## CAUTION

Avoid using heavy gauge or long wiring when possible. Secure all excess wires to prevent snagging of wires during use, potentially causing damage to MōVI Pro, the camera, or the wires.

# BALANCING THE MōVI PRO

MōVI Pro’s balancing procedure is an important part of the setup process. A properly balanced MōVI Pro will offer the best stabilization performance and the longest battery life. For easier balancing, secure MōVI Pro on the MōVI Ring Pro, MōVI Pro Landing Gear, or MōVI Classic Handle with MōVI Dock and C-Stand. Make sure to finalize the camera package build prior to balancing as adding accessories afterward will require the system to be rebalanced for optimal performance. Remove protective covers such as lens caps that will not be used while shooting before balancing the system.

## Items Needed

- » MōVI Pro Gimbal
- » Camera Package\*
- » MōVI Ring Pro or Classical Handle\*
- » MōVI Dock\*

\*These items are not included with the MōVI Pro.

## TILT BALANCE (FRONT-TO-BACK)

1. Open the toggle clamp on the top crossbar and the middle toggle clamp on the bottom crossbar. Hold the camera securely at all times when the toggle clamps are open.
2. Slide the camera forward or backward until the camera remains level.

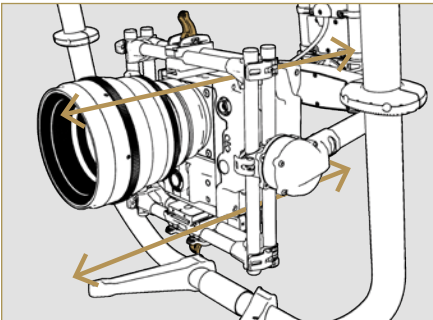

3. Close the top and bottom camera rail toggle clamps.

## TILT BALANCE (VERTICAL AXIS)

1. Rotate the tilt axis so the camera lens points straight up.
2. Open the four vertical adjustment toggle clamps located inline with the tilt motor's axis of rotation.
3. Slide the entire camera cage up or down until the camera remains pointing straight up when released.

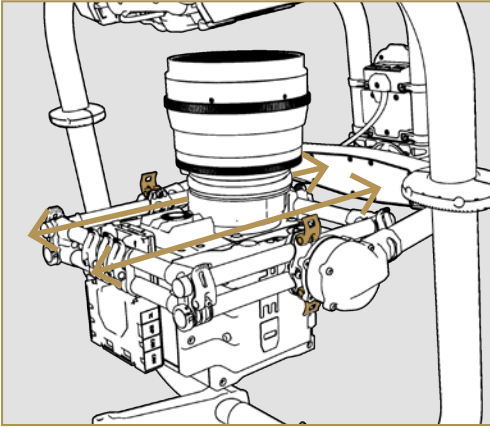

4. Close the toggle clamps.
5. Confirm tilt balance by moving the camera to several tilt angles and confirming the camera remains stationary in the tilt axis once released.

## ROLL BALANCE

1. Open the toggle clamp on the top crossbar and the two outer toggle clamps on the bottom crossbar.
2. Slide camera and platform side-to-side until the camera does not roll once released.

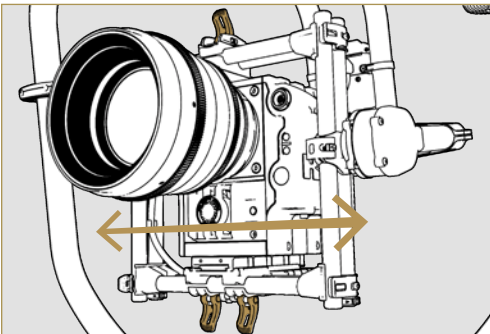

3. Close the top and bottom camera rail toggle clamps.
4. Confirm roll balance by moving the camera to several roll angles and confirming the camera remains stationary in the roll axis once released.

## PAN BALANCE

1. Mount the MōVI Pro in the stand.
2. Align the MōVI Pro such that the camera lens is lined up with the handle bar's cross beam.
3. Use the handle to tilt the MōVI Pro 5 to 10 degrees and observe which way pan rotates.

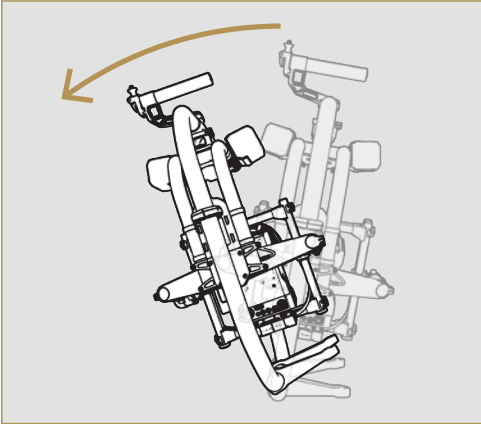

- a. If the lens points to the low side, it indicates the MōVI Pro is nose heavy and the pan arm needs to slide backwards.
  - b. If the lens points to the high side, it indicates the MōVI Pro is tail heavy and the pan arm needs to slide forwards.
4. Open the two toggle clamps underneath the battery trays which secure the pan arm in place.

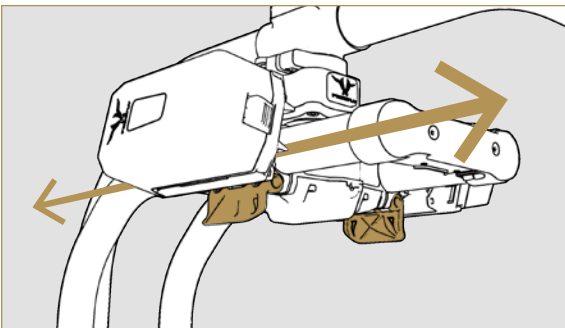

5. Slide the gimbal in the direction needed as indicated in Step 3 and repeat the process until the gimbal does not swing left or right when tilting about the pan axis.
6. Close the two pan toggle clamps and confirm that the camera does not swing left or right when the MōVI Pro is tilted 5 to 10 degrees.

# TUNING THE MōVI PRO

Once the MōVI Pro is balanced, it will need to be tuned. This maximizes the stability and will allow for the smoothest camera movements possible.



Hardware that is mounted to the camera or the MōVI Pro must be firmly secured; loose hardware can limit the stabilization performance by causing unwanted vibrations during the tuning process.

## BASIC TUNING

1. Make sure the camera payload, including all accessories are in place, tightly secured, and well-balanced.
2. Turn on the MōVI Pro by pressing the power button.
3. Use an Android or iOS mobile device to connect to MōVI Pro by selecting “Connect” on the app’s home screen and then choosing the MōVI Pro you are using.
4. Once the connection has been established, open the Tuning Menu under “Configurations.”
5. In order for Autotune to work properly, the camera should be completely free to move.
6. The Autotune feature’s margin of error can be adjusted to reach a higher Autotune Percentage. This will increase the gimbal’s performance but can affect the gimbal’s sensitivity to being unbalanced. Refer to the table below for suggested Autotune Percentages.
7. Start Autotune to tune the Pan, Tilt, and Roll stiffness and filter values of the MōVI Pro.
8. After the Autotune process is complete, test the MōVI Pro for vibrations or oscillations during use. If any vibrations or oscillations exist, determine what axis they are related to and reduce the stiffness of the axis using the Tuning Menu on the app.
9. If the vibrations and oscillations continue, refer to the Advanced Tuning guide.

MōVI PRO CONFIGURATION	SUGGESTED AUTOTUNE PERCENTAGE
Full cage, connected to the top and bottom of the camera; most standard configurations.	70.0%



**NOTE**

Autotuning can also be accessed and initiated through the display screen on the GCU for convenient autotuning when a mobile device is not available.

## ADVANCED TUNING

The advanced tuning options give the user direct control over the MōVI Pro's camera stabilization. This allows users to customize the MōVI Pro to meet their exact needs with features such as Filters, Jolt Rejection, and more. Advanced tuning is not recommended for normal usage.

### FILTERS

The MōVI Pro has a number of software filters that are applied to remove unwanted signals from the system. The Filter settings are the second most important setting for achieving maximum stabilization performance. The purpose of the filters is to eliminate noise and vibration due to structural resonances in the camera, lens, or gimbal. Setting the filters too high or too low can cause signal disturbances that can reduce the overall stabilization.

#### 1. **Pan, Roll, and Tilt Filters**

These control the strength of the filter that is applied to the motor controller signal. The filters apply to each respective axis individually and can be found under the Main page of the Tuning menu.

#### 2. **Gyro Filter**

This controls the strength of the filter applied to the Inertial Measurement Unit's (IMU) signal. Adjusting the Gyro filter can be done by going to the "Advanced" page under the tuning menu and selecting Gyro Filter. This filter applies to all three axes.



## TUNING FILTERS



It will take experience to recognize the symptoms of too-high or too-low filters and trial-and-error to find the optimum values for a particular setup.

1. If the gimbal is vibrating at a high frequency after tuning, increase the filter values.
2. If the gimbal is oscillating or rocking at a low frequency after tuning, decrease the filter values.

## HOLD STRENGTH

While Stiffness values set how much the camera resists moving (with respect to the outside world), Hold Strength sets how aggressively it tries to return to its target position if it is displaced. Indirectly, this also sets how aggressively MōVI Pro follows orientation commands from a second operator using a MōVI Controller or MIMIC. The default Hold Strength values are set to thirty (30) for the MōVI Pro. Increasing Hold Strength has pros and cons that should be considered depending on the shooting situation.

### Higher Hold Strengths PROS

- » Better rejection of disturbances, such as wind, cable tugging, and inertial forces due to imbalance.
- » Better performance at long focal length.
- » Faster tracking of commands from a second operator using a MōVI Controller or MIMIC.

### Higher Hold Strengths CONS

- » Disturbances that do make it through can lead to jolts, since the camera will react faster to outside forces. This can be limited through Jolt Rejection. See page 66.
- » Possibility of overshoot if the second operator stops a pan or tilt abruptly.

## TUNING HOLD STRENGTH

1. To tune hold strength, increase the hold strength of an axis and test its response to a disturbance.
2. If the axis returns to its original position too slowly, increase the hold strength.
3. If the axis overshoots its original position, decrease the hold strength.
4. The final value should be set by weighing the Pros and Cons and testing the setup to see if the MōVI Pro behaves as desired.

## **JOLT REJECTION**

To help enable higher Hold Strength settings while mitigating some of the cons listed above, Jolt Rejection can sense jolts and soften the gimbals recovery effort.

### **Tuning Jolt Recovery**

Jolt Rejection helps prevent the MōVI Pro from overshooting its target orientation when responding to a sudden disturbance. A higher Jolt Rejection value increases the softening of the response; however, values that are too high can cause the MōVI Pro to react too slowly to disturbances.

## **MAX CONTROL RATE**

The maximum rate of camera movement can be used to enable higher Hold Strengths while reducing the possibility of overshoot. This is especially helpful when shooting with longer focal lengths.

### **Tuning Max Control Rate**

1. To increase the control over the camera's movements, increase the Max Control Rate.
2. To increase the smoothness of the camera's movements, decrease the Max Control Rate. This will reduce the operator's control over the camera's movements.

### **Max Roll Angle**

The Max Angle Roll will set a maximum angle between the roll axis and the joint's zero degree angle; this can be used to create a Majestic Roll effect for the MōVI Pro.

## **MōVI PRO SETUP COMPLETE**

Once you have adjusted the MōVI Pro's parameters to suit your requirements, setup is complete!

# UPDATING THE MōVI PRO

The MōVI Pro will arrive with the latest firmware already installed, so updating is not required before the MōVI Pro is initially ready for use. When future firmware versions are released, users can update the MōVI Pro using the following steps.

1. Download the latest version of the MōVI Pro app to your mobile device from the App Store or Google Play.



2. Turn on the MōVI Pro, and make sure it is fully charged and has finished booting.
3. Open the MōVI Pro app on your mobile device and it connect to the MōVI Pro.
4. If there is a new firmware update, your mobile device will prompt you to update the MōVI Pro.
5. If you wish to update the MōVI Pro select "update" to initiate the update process.
6. Once the update has completed, reboot the MōVI Pro.



Do not power down the MoVI Pro, remove its microSD card, or interrupt its connection with the mobile device for the duration of the update.

# ECOSYSTEM SETUP

The MōVI Pro was designed to integrate seamlessly with the current ecosystem of Freefly products. Through the use of our industry favorite Toad In The Hole connector and features specifically designed and programmed for product synthesis, the MōVI Pro is the world’s most versatile camera movement system.

## MIMIC + MōVI PRO

MIMIC is the next generation in the MIMIC family of products; an added display with controls, upgraded processor, and new features make it the most intuitive camera controller available. To use a MIMIC with your MōVI Pro, you will first have to pair the devices as described in the following steps.

### SETTING UP MIMIC BETA AND MōVI PRO

1. Turn on the MIMIC by pushing the Power button. Use the display controls to move to the Radio Screen.

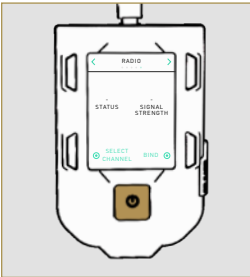

2. Select "Select Channel" and choose the channel you wish to use to pair the MIMIC with your MōVI Pro.

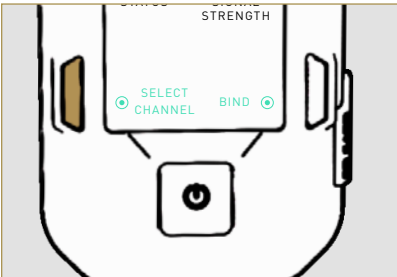

3. Turn on the MōVI Pro and proceed to the Radio Screen. Use "Select

Channel” to set the MōVI Pro to the same channel as the MIMIC. Press the Bind button on the MōVI Pro; a progress bar will appear showing the amount of time remaining to pair the device to a MIMIC.

4. Press the Bind button on the MIMIC within 5 seconds of pressing the Bind button on the MōVI Pro. The devices will pair automatically.

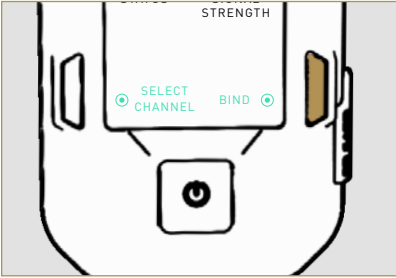

MIMIC uses a very powerful wireless transmitter to control the MoVI Pro; when this transmitter is in close proximity to its receiver, the receiver can be oversaturated with input causing unwanted movements. This is normal behavior for power wireless transmitters.

## MIMIC BETA + MōVI PRO

The MIMIC Beta Controller comes pre-bound to the Freely Receiver included in the MIMIC Beta package. If you are using the bound receiver provided with the MIMIC Beta, follow steps 1-4 to connect and power both products. Users trying to bind a MIMIC Beta to a unbound receiver must follow all steps 1-9.

### SETTING UP MIMIC BETA AND MōVI PRO

#### Items Needed

- » MōVI Pro
- » MIMIC Beta\*
- » MōVI RX\*

\*These items are not included with the MōVI Pro.

1. Ensure that the MIMIC Beta TX and Freely RX are set to the same channel. The channel is set by a small dial located on the TX and RX.

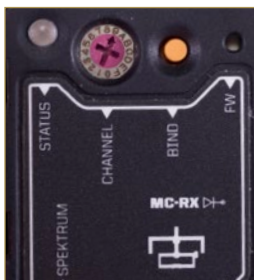

2. Ensure the Freefly RX's 5 pin connector is plugged into the COM1 port on the MōVI Pro GCU.



3. Ensure the 5 pin connector from the MIMIC Beta is plugged into the MIMIC TX. Power the MIMIC Beta by connecting the USB to the battery and the 3-pin connector to the MIMIC Beta.



4. Turn on the MōVI Pro and make sure the MIMIC Beta TX and Freefly RX status LED are illuminated, indicating both have power.
5. Press and hold the Bind button on the Freefly RX for 2-3 seconds before releasing it.



6. Wait for the RX's status LED to slowly flash orange. This indicates the TX has been found.
7. Press and hold the Bind button on the MIMIC Beta TX until the status LED turns orange. The MIMIC Beta TX and Freefly RX are now binding.



8. Once successful, the lights on both the MIMIC Beta TX and Freefly RX will turn green.
9. If Binding fails, repeat steps 5-7.



For instructions on the operating procedure and other information on the MIMIC Beta please visit [freeflysystems.com/software-manuals](https://www.freeflysystems.com/software-manuals) and download the MIMIC Beta User Manual.

## MōVI CONTROLLER + MōVI PRO

A MōVI Controller can take complete control of the MōVI Pro's camera movement, settings, and receive telemetry from the camera, allowing users to make on the fly adjustment to key MōVI Pro parameters.

### SETTING UP MōVI CONTROLLER AND MōVI PRO

## Items Needed

- » MōVI Pro
- » MōVI Controller\*
- » MōVI RX\*

\*These items are not included with the MōVI Pro.

1. Select the desired channel on MōVI RX and connect it to the COM1 port on the MōVI Pro GCU.



2. Power up the MōVI Controller and set the channel on MōVI Controller to match the channel on the MōVI RX.
  - a. Home > Radio Config > Channel (cycle and select with Menu Set knob)
3. Set Radio Action to Write.
  - a. Home > Radio Config > Radio Action (select Write with Menu Set knob)
4. Press Menu Set knob to enact the write command.
5. Power up the MōVI Pro and hold the Bind button on the MōVI RX for 2-3 seconds.
6. Set Radio Action to Bind.
  - a. Home > Radio Config > Radio Action (select Bind with Menu Set knob)
7. Press Menu Set knob to enact Bind command.
8. Wait 20 seconds until MōVI Controller and MōVI RX are bound.



For instructions on the operating procedure and other information on the MōVI Controller, please visit [freeflysystems.com/software-manuals](https://freeflysystems.com/software-manuals) and download the MōVI Controller User Manual.



# FUTABA OR SPEKTRUM RADIO + MōVI PRO

## BINDING PROCEDURE

1. Bind an approved Spektrum or Futaba RC radio with it's receiver using the instructions provided by the respective RC radio manufacturer.
2. Use the MōVI Pro App to connect to the MōVI Pro and select correct radio type option under the Dual Op menu.
3. Plug the receiver into COM2 port on the GCU and map your RC radio's channels to the correct outputs using the MōVI Pro App.
4. Confirm mapping by testing the RC radio and observing the MōVI Pro's response.

## MULTI CONTROLLER SETUP

The MōVI Pro was designed to support multi-controller network to achieve advanced control from multiple remote devices. This means a MIMIC can be used to control gimbal orientation while simultaneously operating a camera's FIZ through MōVI Controller.

### MōVI CONTROLLER + MIMIC + MōVI PRO

1. Setup MIMIC and MōVI Pro as described in the previous section.
2. Setup MōVI Controller on COM1 as described in the previous section.

In this configuration MIMIC controls the MōVI Pro's orientation while the MōVI Controller controls FIZ.

### MōVI CONTROLLER + SPEKTRUM/FUTABA RADIO + MōVI PRO

1. Setup MōVI Controller on COM1 as described in the previous section.
2. Setup Spektrum/Futaba on COM2 as described in the previous section.

In this configuration the Spektrum/Futaba radio will control the MōVI Pro's orientation while the MōVI Controller controls FIZ.

### MōVI CONTROLLER + 2ND MōVI CONTROLLER + MōVI PRO

1. Setup MōVI Controller on COM1 as described in the previous section.
2. Setup a second MōVI Controller on COM2.

In this configuration the second MōVI Controller controls the MōVI Pro's orientation while the first MōVI Controller controls FIZ.



When a single MōVI Controller is connected to the MōVI Pro it will control both the orientation of the gimbal and all FIZ control. Adding a second MōVI Controller to COM 2 will reassign orientation control to the second MōVI Controller.

## ALTA + MōVI PRO

Due to the unique design of the ALTA multirotor family, the MōVI Pro can be mounted on top of the ALTA in SkyView or underneath the ALTA in GroundView.



To use the MōVI Pro in Skyview, do not attach the MōVI Pro Aero Landing gear to the MōVI Pro.



Make sure that both thumbscrews on the forward landing gear are firmly tightened before every flight. Loose thumbscrews may result in landing gear failure during flight or landing that could lead to a damage to the MōVI Pro, ALTA, or camera package.



Always ensure the MōVI Pro and ALTA are within the Allowable Gross Weight specifications listed in the applicable ALTA 6 or ALTA 8 Aircraft Flight Manual available at [www.freeflysystems.com/software-manuals/](http://www.freeflysystems.com/software-manuals/) before flight.

## SETTING UP MōVI PRO + AERO LANDING GEAR

### Items Needed

- » MōVI Pro
- » MōVI Dock\*
- » MōVI Pro Aero Landing Gear\*
- » 2.5mm Hex driver

\*These items are not included with the MōVI Pro.

1. Attach the long carbon fiber tubes to the landing gear cross beam to assemble the front landing gear. Use the levers to hand tighten the rods into place.

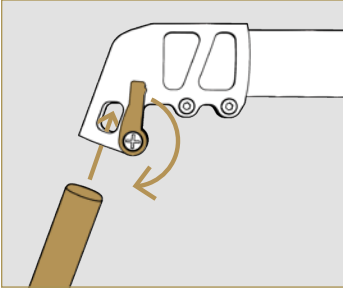

2. Place MōVI Pro on a MōVI Dock and use four M3 screws to attach the front landing gear to the front of the MōVI Pro's Pan arm.

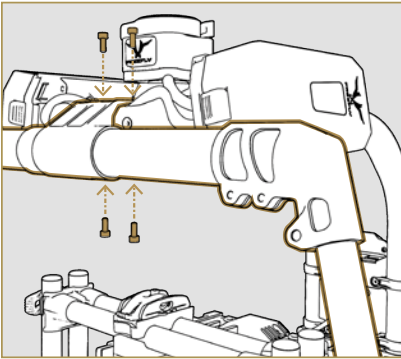

3. Slide the rear landing gear into the slot underneath the GCU from either side and secure it with two M3x8 screws.

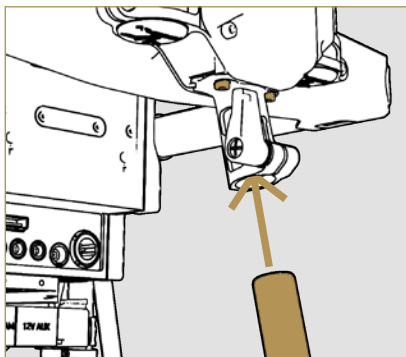
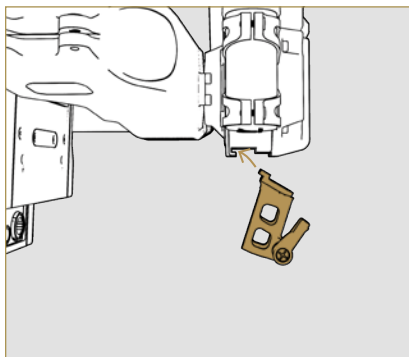

Attaching the rear landing gear does not require excessive force. Always slide the rear landing gear into its slot using a lateral motion.

## GROUNDVIEW

### Items Needed

» MōVI Pro + Landing Gear\*

» ALTA\*

\*These items are not included with the MōVI Pro.

1. Connect the ALTA with the MōVI Pro using the TITH connector.

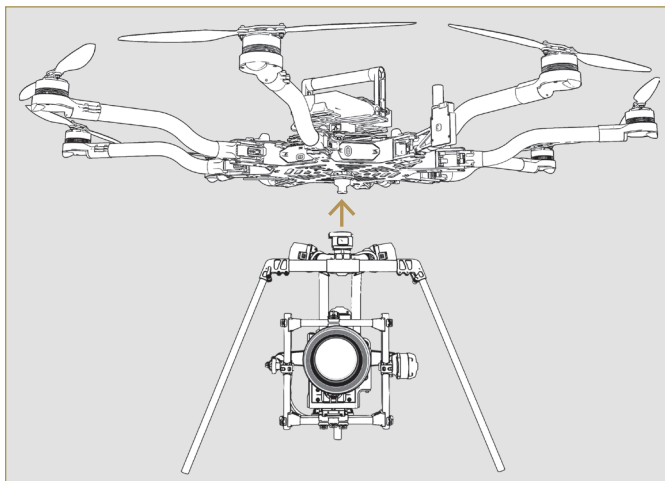

2. Lock the TITH to secure the MōVI Pro in place, and the MōVI is now flight ready!

## SKYVIEW

### Items Needed

- » MōVI Pro
- » ALTA SkyView Landing Gear\*
- » ALTA\*

\*These items are not included with the MōVI Pro.

1. Attach SkyView landing gear to the ALTA using the TITH connector underneath the ALTA.

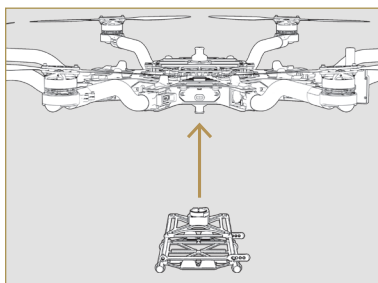

2. Remove the Quick Release Top Handle by disconnecting it from the TITH connector on top of the ALTA.

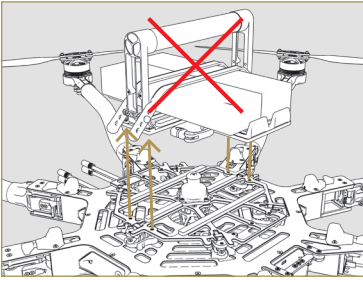

3. Attach the MōVI Pro to the top of the ALTA and lock into place using the upper TITH connector.

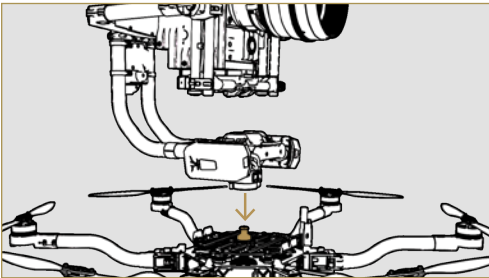

4. The MōVI Pro is now flight ready.



For instructions on the operating procedure and other information on the ALTA, please visit [freeflysystems.com/software-manuals](https://freeflysystems.com/software-manuals) and download the ALTA Aircraft Flight Manual.

## TERO + MōVI PRO

Place the MōVI Pro in the middle of a stunt scene for a dynamic low camera angle shot while maintaining complete control and stability.

### Items Needed

- » MōVI Pro
- » TERO\*

\*These items are not included with the MōVI Pro.

1. Connect the TERO with the MōVI Pro using the TITH connector.

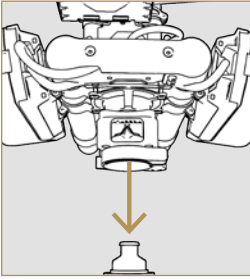

2. Lock the TITH to secure the MōVI Pro in place, and the MōVI Pro is now ready to drive!



USING  
MŌVI PRO



# CONFIGURING THE MōVI PRO

---

## Setting Configurations

MōVI Pro Embedded Display Configurations	82
MōVI Pro App Configurations	87
FIZ Motors Configurations	90
Mode Configuration	92

Configuring the MōVI Pro is easy. With a built-in control screen and mobile app that can assume complete control over the MōVI Pro's settings, a user can adjust tuning values, remote controller setup, and switch modes on the fly. This grants the user complete freedom of customization and allows for endless creativity. The following section will guide you through the configuration options available to a MōVI Pro user.

# APPS AND SOFTWARE

## SETTING CONFIGURATIONS VIA THE MōVI PRO DISPLAY

The MōVI Pro is equipped with a built-in display and display navigation system. This allows a user to check the MōVI Pro's system status and make quick adjustments to tuning, tilt mode, radio options, and more.

### MONITOR SCREEN

This screen monitors the MōVI Pro's battery levels and system details including warnings and device status.

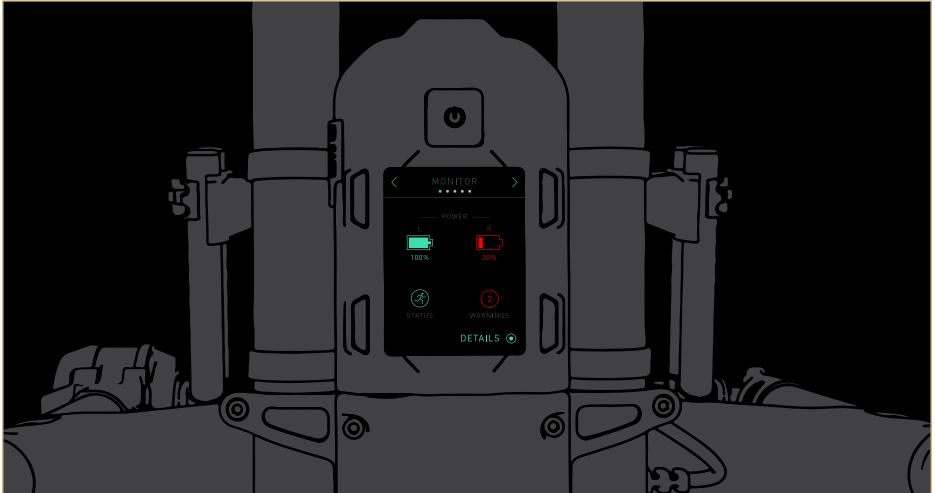

OPTIONS	DESCRIPTION
1. Left Battery Power (%)	Displays the power remaining in the left battery as a percentage.
2. Right Battery Power (%)	Displays the power remaining in the right battery as a percentage.
3. Next Screen Button	Takes users to the next GCU screen.
5. Details Button	Takes user to the MōVI Pro's component status.
7. Status Icon	Displays the current status of the MōVI Pro, for example whether booting or stabilization has initialized.
8. Warning Icon	Displays warnings about the MōVI Pro. To view these warnings select the Details button.

## TUNING SCREENS

These screens allow users to autotune or perform manual tuning adjustments to the MōVI Pro without needing to connect to another device.

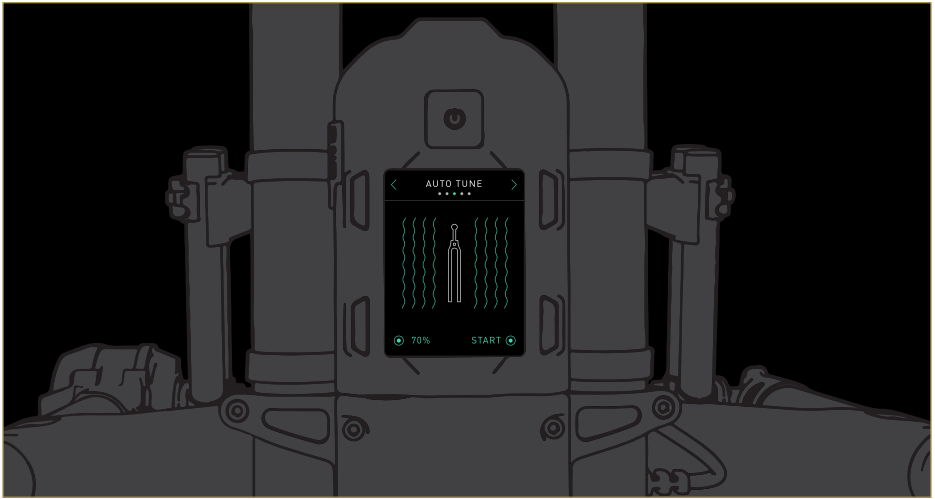

### Autotune Screen

OPTIONS	DESCRIPTION
1. Percentage	Set Autotune percentage, a higher value will result in a configuration closer to the max stiffness.
2. Start	Initiates the autotuning feature on the MōVI Pro and displays a progress bar.
3. Next Screen Button	Takes users to the next GCU screen.
4. Previous Screen Button	Takes users to the previous GCU screen.

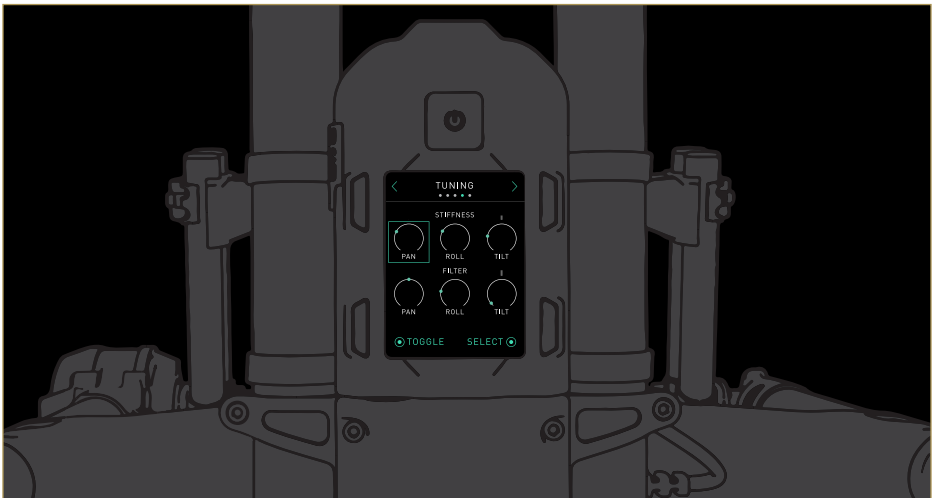

## Tuning Screen

OPTIONS	DESCRIPTION
1. Toggle	Toggles through the stiffness and filter parameters for each axis.
2. Select	Selects the highlighted parameter and moves to the respective parameter adjustment screen.
3. Stiffness Values (Pan, Roll, Tilt)	Displays a visual of the Pan, Roll, or Tilt stiffness values.
4. Filter Values (Pan, Roll, Tilt)	Displays a visual of the Pan, Roll, or Tilt filter values.
5. Next Screen Button	Takes users to the next GCU screen.
6. Previous Screen Button	Takes users to the previous GCU screen.

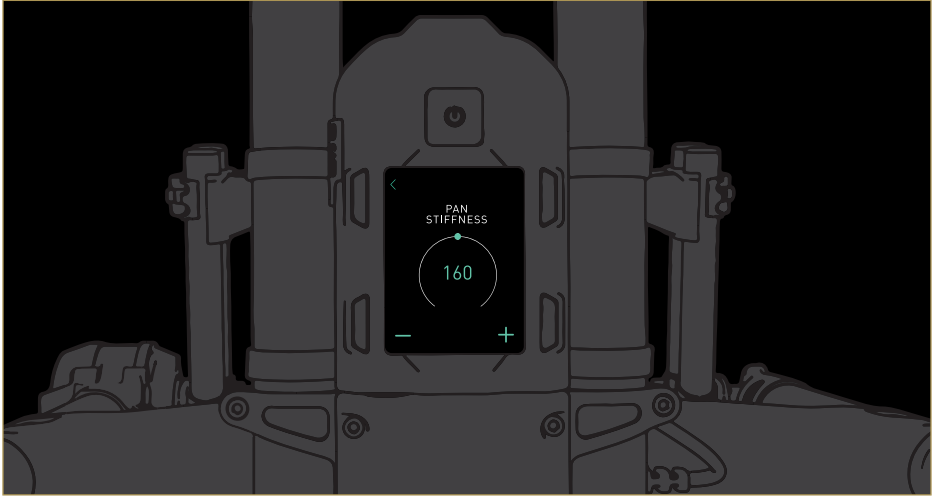

## Stiffness/Filter Parameter Adjustment Screen

OPTIONS	DESCRIPTION
1. Previous Screen Button	Takes users to the previous GCU screen.
2. "+" Button	Increases the selected stiffness or filter value by (1) if pressed and (5) if held.
3. "-" Button	Decreases the selected stiffness or filter value by (1) if pressed and (5) if held.

## BALANCE SCREEN

This screen allows users to see the MōVI Pro's balance quality by displaying the amount of motor correction needed to keep the camera stabilized. A perfectly balanced camera will show stationary white markers at the middle of the Pan, Roll, and Tilt bars on the balance screen.

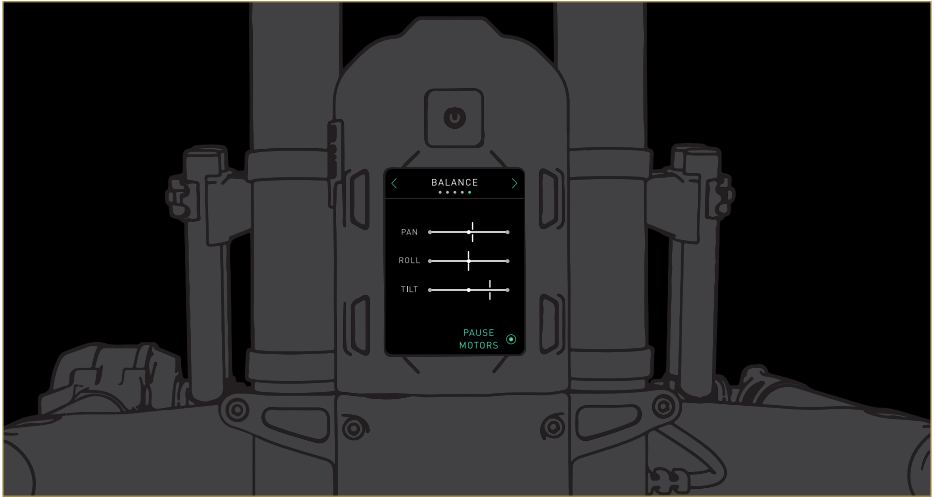

OPTIONS	DESCRIPTION
1. Pan, Roll, and Tilt Visuals	Displays the real-time motor activity needed to maintain camera stability.
2. Pause/Activate Motors	To allow for re-balancing of the gimbal, this temporarily turns off all motors until the button is pressed again.
3. Next Screen Button	Takes users to the next GCU screen.
4. Previous Screen Button	Takes users to the previous GCU screen.

## TILT MODE SCREEN

This screen allows users to control the MōVI Pro's tilt mode without the need of a second device.



OPTIONS	DESCRIPTION
1. Tilt Mode Status	Displays the current Tilt Mode status.
2. Majestic Angle/Smooth Lock	Switches the Tilt Mode from Smooth Lock to Majestic Angle. Pressing the same button will return the Tilt Mode to Smooth Lock.
3. Next Screen Button	Takes users to the next GCU screen.
4. Previous Screen Button	Takes users to the previous GCU screen.

## RADIO SCREEN

This screen allows users to select the MōVI Pro's receiver channel and bind the MōVI Pro to a MōVI Controller, MIMIC, or approved radio control device.

OPTIONS	DESCRIPTION
1. Radio Statuses	Displays the signal status and strength.
2. Select Channel	Allows the user to select the MōVI Pro's receiver channel.
3. Bind	Allows the user to bind the MōVI Pro to a Dual-Op device.
4. Previous Screen Button	Takes users to the previous GCU screen.

# SETTING CONFIGURATION VIA THE FREEFLY MōVI PRO APP

The Freefly MōVI Pro App grants users complete control over MōVI Pro and all of its settings. The app is designed to be intuitive and easy to use while not limiting MōVI Pro's versatility.



Any configuration created by a user can be stored by the MōVI Pro App via the Presets menu, which is accessible through the caret at the top of the Configuration menu. Select "New" and input a filename to create a configuration of the current settings. Once created, the configuration can be renamed, applied, or deleted through the Presets menu.

## CONNECTION TO THE MōVI PRO USING BLE

Before you can use a mobile device to configure your MōVI Pro, you must first connect the two devices using BLE. The following instructions will help you connect your MōVI Pro to any compatible iOS or Android device.

1. Turn on the MōVI Pro by pushing the power button and allow the gimbal to initialize.
2. Open the Freefly MōVI Pro app on an iOS or Android mobile device. Connect to the MōVI Pro by selecting "Connect" on the app's home screen and then choosing the MōVI Pro you are using.

# GENERAL MENU

MōVI Pro's settings are accessible through the General icon under the Configurations menu.

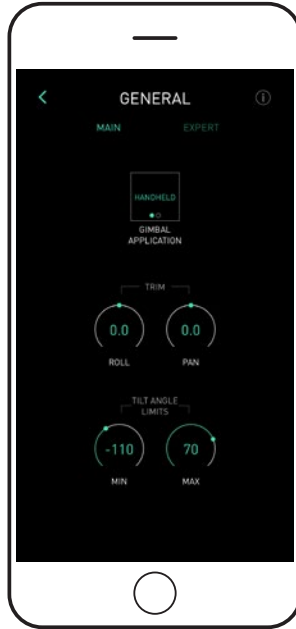

## Main Panel

OPTIONS	DESCRIPTION
1. Gimbal Application Icon	Select whether the MōVI Pro will be used in "Handheld" or "Airborne" mode. This selection will affect the center position of the Mode switch in while in Dual-Op by enabling Majestic Pan in "Handheld" mode or locking each axis for take-off and landing in "Airborne" mode.
2. Roll Trim	Increase or decrease the roll trim angle to level the camera during Majestic Mode.
3. Pan Trim	Increase or decrease the pan trim angle and set a new neutral pan angle when the MōVI Pro is hard mounted to a multirotor so that the MōVI Pro is aligned with the front of the multirotor.
4. Min Tilt Angle Limit	Set the minimum angle of the tilt axis (downward tilt). This can be used to place a soft stop and prevent a camera, lens, or wiring from becoming a mechanical stop.
5. Max Tilt Angle Limit	Set the maximum angle of the tilt axis (upward tilt). This can be used to place a soft stop and prevent a camera, lens, or wiring from becoming a mechanical stop.



## Expert Panel

OPTIONS	DESCRIPTION
1. Heading Assist	Use to orient the MōVI Pro under different circumstances. "Fixed Mount" should be used when the MōVI Pro is stationary to avoid any pan drift; "GPS" should be used in high acceleration situations commonly observed when using the MōVI Pro with an aerial platform, and "Compass" can be used when the MōVI Pro is handheld or aerial.
2. Declination	Set the declination angle when using the "Compass" Heading Assist mode. A declination angle is used to adjust for the Earth's magnetic variance due to global position.
3. Calibration	Calibrate the compass on the MōVI Pro to increase the performance of the Compass Heading Assist mode. Follow the instructions provided by the app when initializing a compass calibration.
4. Motion Booting	Enable "Motion Booting" to allow MōVI Pro to boot in situations where there is significant movement during the initialization process of the gimbal such as on a boat. For optimum performance in normal use, motion booting should be turned off.
5. Setdown Sleep	Enable "Setdown Sleep" to allow MōVI Pro to enter sleep mode when motors are stalled for more than 4 seconds. MōVI Pro will exit sleep mode when joint motion is detected.
6. Power Supply	Select "LiPo" or "External" as the MōVI Pro's Power supply.
8. Logging Rate	Select MōVI Pro's data logging rate.
9. Data Logging	Enable the MōVI Pro's data logging function via a MicroSD card in the GCU.
10. Pan Shaky Cam	Enable Shaky Cam for the pan axis. Shaky Cam deliberately disturbs the orientation of the gimbal to create a lead or lag effect.
11. Tilt Shaky Cam	Enable Shaky Cam for the tilt axis. Shaky Cam deliberately disturbs the orientation of the gimbal to create a lead or lag effect.

# FIZ SETTING CONFIGURATION VIA THE MōVI CONTROLLER

Use the MōVI Controller for complete command over your MōVI Pro’s FIZ motor setup. Real time focus, iris, and zoom control in addition to individual axis configuration tools provide users with a fully customizable FIZ system.

## FIZ CONFIGURATIONS

These configurations can only be changed using the MōVI Controller and MōVI Pro in tandem.

### FIZ Config

OPTIONS	DESCRIPTION
Settings Action	Select MōVI Controller setting action. This only affects settings that are persistent and not state dependent.
Camera Type	Select the camera type so the MōVI Controller can use the correct signal protocol when communicating with the camera. This must be done in addition to using the correct remote R/S or control cable.
Focus Scale	Set the focus scale to Linear or Stretched. Stretched causes more of the focus knob travel to be used in the longer focal distance range where the scale gets compressed.
Focus Std/Metric	Select Standard or Metric units for focus distance measurements.
Lens Unit Focus	Set lens focus position to physical units or percent. A lens must be selected on the MōVI Controller to show physical units.
Lens Unit Iris	Set lens iris position to physical units or percent. A lens must be selected on the MōVI Controller to show physical units.
Lens Unit Zoom	Set lens zoom position to physical units or percent. A lens must be selected on the MōVI Controller to show physical units.

## FIZ Axis Config

OPTIONS	DESCRIPTION
Axis Selection	Select the FIZ axis that will be edited.
Settings action	Select MōVI Controller setting action. This only affects settings that are persistent and not state dependent.
Motor Model	Select motor model to adjust control loop gains, fault settings and other settings that are specific to the motor.
Dampening	Change the strength of the low pass filter being used on the input control knob.
Knob Direction	Change the control direction of the input interface.
Motor Direction	Change the motor direction.
Torque Limit	Limit the max amount of current allowed to FIZ motor.
Speed Limit	Limit the max rotational speed of the FIZ motor.
Control Input	Change the control input interface for a FIZ axis. Default Input Interface <b>Focus:</b> Large knob <b>Iris:</b> Small Knob <b>Zoom:</b> Rocker

# MODES

The creation of professional cinematographic content is made simple through the use of MōVI Pro's modes from intuitive orientation control, to custom dynamic time lapses, and more. All of the MōVI Pro's modes are accessible through the MōVI Pro app and the MōVI Controller.

## MAJESTIC MODE

Majestic Mode allows a single user to have complete control over the MōVI Pro by stabilizing the camera and following movement inputs from the user. The Majestic Mode GUI allows a user to configure the Majestic Mode to suit a particular shot.

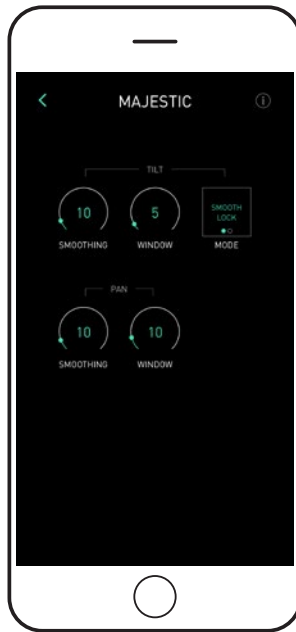

### OPTIONS

1. Tilt Smoothing

2. Tilt Window

3. Tilt Mode

### DESCRIPTION

Adjust the smoothing value applied to the tilt axis. Smaller values will result in gimbal movements that are more directly related to handle movements.

Define the range of handle movement that will be ignored by the MōVI Pro in Majestic Mode. This will allow for unintentional movements to be ignored.

Select "Smooth Lock" or "Majestic Angle" as the tilt mode. Smooth Lock will maintain a set tilt angle regardless of handle position. Majestic Angle links the tilt axis to the handle movement, allowing a single user to control the tilt angle.

## OPTIONS

## DESCRIPTION

### 4. Pan Smoothing

Adjust the smoothing value applied to the pan axis. Smaller values will result in gimbal movements that are more directly related to handle movements.

### 5. Pan Window

Define the range of handle movement that will be ignored by the MōVI Pro in Majestic Mode. This will allow for unintentional movements to be ignored.

## TIMELAPSE MODE

Timelapse mode lets users create stunning camera movements for timelapses in seconds. Users can create and edit keyframes of the desired motion and quickly adjust variables such as Timelapse Interval and Timelapse Duration.



### NOTE

Timelapse works best when Heading assist is set to "Fixed Mount". This can be set on the Expert panel in the General Menu.

## Path Panel

OPTIONS	DESCRIPTION
1. Preview	Initiate condensed preview of the timelapse path.
2. Start	Initiate the timelapse progression through all keyframes using the total duration calculated on the Setup panel.
3. Clear	Delete all keyframes.
4. Keyframe Display	Display each of the keyframes being used and the pan and tilt path used to travel from one keyframe to the next.
5. Virtual Joystick	Use to set or edit keyframe positions.
6. Add, Set, Done	Use to add and edit the timelapse keyframes. Select "Add" to place a keyframe in the current pan and tilt orientation of the MōVI Pro. To reposition a keyframe tap the desired keyframe on the keyframe display and reposition it using the virtual joystick, the MōVI Controller, or an authorized 3rd party radio controller. Once desired keyframes are repositioned, select "Set" and then "Done" to exit the keyframe editing mode.



MōVI Pro Keyframe positions may be set by hand or remotely via the MōVI Controller or an authorized 3rd party radio controller.

## Setup Panel

OPTIONS	DESCRIPTION
1. Timelapse Interval	Select the time interval between shots. An intervalometer (not included) must be used to operate the camera's shutter and set to the same time interval used in the app.
2. Target Clip Length	Select the desired length of the video resulting from the timelapse images.
3. Target Clip FPS	Select the desired frames per second (FPS) in the video resulting from the timelapse images.
4. Total Photos	Displays the total number of photos that will be taken during the timelapse. $\text{Total Photos} = \text{Target Clip Length} * \text{Target Clip FPS}$
5. Timelapse Duration	Displays the time duration of the timelapse. $\text{Timelapse Duration} = \text{Timelapse Interval} * \text{Target Clip FPS} * \text{Target Clip Length}$
6. Pan Curve Fit	Toggle between linear and cubic paths between keyframes on the Pan axis.
7. Tilt Curve Fit	Toggle between linear and cubic paths between keyframes on the Tilt axis.

# DUAL OP MODE

Dual Op mode allows one operator to concentrate on framing and lens control while another operator has control of movement. Dual Op is possible using the MIMIC, MōVI Controller, or certain 3rd party RC controllers.

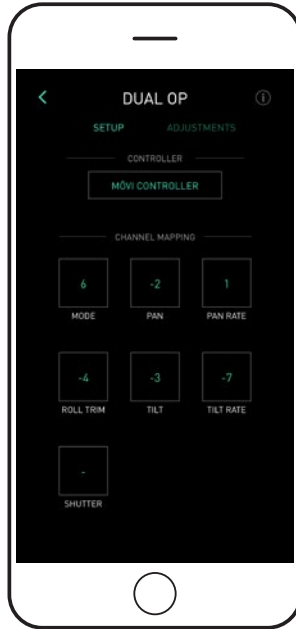

## Setup Panel

OPTIONS	DESCRIPTION
1. Controller	Select the type of radio controller being used in Dual Op mode.
2. Bind	Start binding procedure with the Dual Op device. The app will provide all instructions needed to bind the remote controller to the MōVI Pro.
3. Mode	Select the radio channel for Gimbal Mode. This should be mapped to a three-position switch to control modes (Kill, Majestic, Dual Op).
4. Pan	Select the radio channel for pan. It is recommended that the pan should be mapped to the right joystick's horizontal axis.
5. Pan Rate	Select the radio channel for pan rate. It is recommended that the pan rate should be mapped to the left joystick's vertical axis or a rotary knob.
6. Roll Trim	Select the radio channel for roll trim.
7. Tilt Curve Fit	Select the radio channel for tilt. It is recommended that the tilt should be mapped to the right joystick's vertical axis.
8. Tilt Rate	Select the radio channel for tilt rate. It is recommended that the tilt rate should be mapped to the left joystick's vertical axis or a rotary knob.
9. Shutter	Select the radio channel for remote shutter release or start/stop function.

Use the following guide to map Spektrum and Futaba radios.

#### Mapping for Spektrum Transmitter

RADIO TYPE	S. DSMX 2048
Map Remote Mode	6
Map Remote Pan	-2
Map Remote Pan Rate	1
Map Remote Tilt	-3
Map Remote Tilt Rate	-7
Map Remote Roll Trim	-4



**NOTE**

#### Mapping for Futaba Transmitter

RADIO TYPE	S. BUS
Map Pan Rate Clamp	-7
Map RC Mode	-5
Map RC Pan	1
Map RC Roll Trim	4
Map RC Tilt	2
Map RC Tilt rate Clamp	6



**NOTE**

The MōVI Controller does not require channel mapping through the MōVI Pro App. All channel mapping for the MōVI Controller is done through the controller itself.



## Adjustments Panel

OPTIONS	DESCRIPTION
MIMIC Mode	Select the mode (Direct, Level Roll, Majestic Pan, Majestic Pan/Tilt) in which the MIMIC controls the MōVI Pro. <ul style="list-style-type: none"><li>» Direct mode allows the MIMIC to control MōVI Pro's pan, tilt, and roll movement.</li><li>» Level Roll mode allows the MIMIC to control the MōVI Pro's pan and tilt movement.</li><li>» Majestic Pan mode allows the MIMIC to control the MōVI Pro's pan movement in majestic mode.</li><li>» Majestic Pan/Tilt mode allows the MIMIC to control the MōVI Pro's pan and tilt movement in majestic mode.</li></ul>
Shutter Mode	Select the shutter type (Pulsed, Latched, Camera I/F).
Pan/Tilt Speed Adj	Select whether the pan and tilt rates are controlled together (Combined) or separately (Independent).
Tilt Control Mode	Select tilt control mode (Rate, Angle). Angle mode is recommended for single operator multirotor use while Rate mode is recommended for all other situations.
Remote Rate Scale	Select the Remote Rate Scale value. A higher value will increase the maximum pan and tilt rates when in Dual Op mode.
Pan Joystick Smoothing	Sets how much smoothing is applied to the pan joystick in Dual Operator mode. A higher number will apply more smoothing.
Pan Joystick Window	Define a range of pan joystick movement from center that will be ignored.
Pan Joystick Expo	Set the exponential curve value that controls the pan movement. A higher value will make the reduce the sensitivity in the center of the joystick's range and increase the sensitivity toward the edges.
Tilt Joystick Smoothing	Sets how much smoothing is applied to the tilt joystick in Dual Operator mode. A higher number will apply more smoothing.
Tilt Joystick Window	Define a range of tilt joystick movement from center that will be ignored.
Tilt Joystick Expo	Set the exponential curve value that controls the tilt movement. A higher value will make the reduce the sensitivity in the center of the joystick's range and increase the sensitivity toward the edges.

# TARGET MODE

Target Mode allows the MōVI Pro to track a GPS coordinate or the Freefly MIMIC automatically. In Target Mode, the MōVI Pro autonomously frames the subject using the positional data from the MōVI Pro and/or MIMIC sensor.

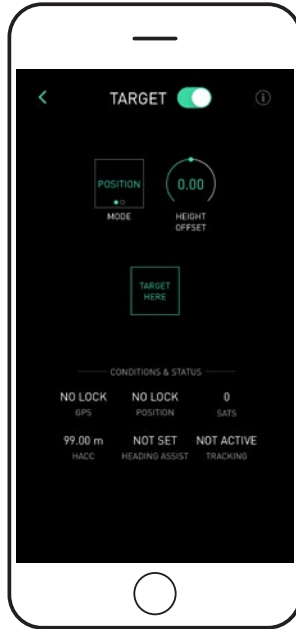

OPTIONS	DESCRIPTION
1. Toggle	Turn Target mode on and off by selecting the virtual toggle.
2. Mode	Select the MōVI Pro’s target. <ul style="list-style-type: none"> <li>Position mode will target a specific location.</li> <li>Position/Alt mode will target a specific location and altitude.</li> <li>Target MIMIC mode will target the location of the bound MIMIC.</li> </ul>
3. Height Offset	Select a height offset for Pos/Alt mode.
4. Target Mode	Mark a the GPS location that MōVI Pro targets while in Pos and Pos/Alt mode.
5. HACC Display	Displays the horizontal accuracy of the GPS.
6. Heading Assist Display	Displays the Heading Assist mode.
7. Tracking Display	Displays the MōVI Pro’s Target mode status.



Target Mode performance relies significantly on the quality of the GPS signal and a good compass calibration. Experimentation with target mode in different situations and environments is recommended before use in productions.



TROUBLESHOOTING  
AND MAINTENANCE

# TROUBLESHOOTING GUIDE

## GIMBAL WON'T TURN ON

POSSIBLE CAUSE	POSSIBLE SOLUTION
Batteries are discharged	Replace discharged batteries with fully charged batteries
Batteries are damaged	Replace all damaged batteries Dispose of damaged batteries properly

## GIMBAL ON BUT NO STABILIZATION ON ONE OR MORE AXIS

POSSIBLE CAUSE	POSSIBLE SOLUTION
Axis Stiffness is set to 0	Use GCU Display or Mobile App to raise the stiffness values on axes with (0) stiffness
A Motor Drive has been reset due to voltage, temperature, or current protection	Restart the MōVI Pro
Dual Operator Radio Controller is in Kill Mode	Use the Mode Switch on the Radio Controller to activate Dual Operator Mode
Gimbal is still initializing	Make sure the gimbal is steady for 5 seconds

## OSCILLATION ON ONE MORE GIMBAL AXIS

POSSIBLE CAUSE	POSSIBLE SOLUTION
Stiffness setting is too high	Reduce the Stiffness setting of the axis that is oscillating using the Tuning menu on the GCU or MōVI Pro app
An Adjustment Clamp is not tightened	Check all Adjustment Clamps for adequate tightness; they must all be locked securely during operation
Camera mounting is not stiff enough	The camera must be mounted rigidly to the Tilt Axis. Use a wedge or spacer under the lens and/or on the sides of the camera to increase mounting stiffness if necessary
Filter settings are incorrect <i>Note: The Gyro and Output filters are advanced settings and should only be modified if other methods of reducing oscillation have failed</i>	If the oscillations are fast (buzzing), try increasing the Filter settings under Expert Settings on the GCU or MōVI Pro App. If they are slow (rocking), try decreasing the Filter settings

## HORIZON (ROLL AXIS) IS NOT LEVEL

POSSIBLE CAUSE	POSSIBLE SOLUTION
Roll Trim not set	Adjust the Roll Trim setting to achieve a level horizon

## HORIZON (ROLL AXIS) IS NOT LEVEL UNDER HARD ACCELERATIONS

POSSIBLE CAUSE	POSSIBLE SOLUTION
GPS signal not present	Wait for GPS status to lock

## NO CONTROL IN DUAL OPERATOR MODE

POSSIBLE CAUSE	POSSIBLE SOLUTION
Dual Operator Radio Controller is off, or set to Kill or Majestic Mode	Turn on Radio Controller and set Mode Switch to Dual Operator (DUAL) Mode
Radio Controller Mapping is misconfigured	If you are using a 3rd party Radio Controller (Spektrum DX7), ensure that the Radio Mapping settings in the GUI are correctly mapped (Refer to the Dual Op Mode Configuration section)

# APPENDIX

## DEFAULT TUNING VALUES

PARAMETER	DEFAULT VALUE
Autotune Percentage	70 %
Declination	0 deg
Gyro Filter	5
Jolt Rejection	0
Map Remote Mode	RC Channel 6
Map Remote Pan	RC Channel -2
Map Remote Pan Rate	RC Channel 1
Map Remote Roll Trim	RC Channel -4
Map Remote Shutter	RC Channel 0
Map Remote Tilt	RC Channel -3
Map Remote Tilt Rate	RC Channel -7
Max Control Rate	200 deg/s
Max Roll Angle	45 deg
Max Tilt Angle	70 deg
Min Tilt Angle	-110 deg
Output Filter	1
Output Pan Filter	10
Output Roll Filter	5
Output Tilt Filter	1
Pan Hold Strength	30
Pan Joystick Expo	10 %
Pan Joystick Smoothing	5
Pan Joystick Window	8 $\mu$ s
Pan Majestic Span	135 deg
Pan Smoothing	10
Pan Stiffness	0
Pan Trim	0
Pan Window	10 deg
Remote Rate Scale	100 %
Roll Hold Strength	30
Roll Stiffness	0
Roll Trim	0
Shaky-cam Pan	0
Shaky-cam Tilt	0
Shutter Speed	0.5 s
Target Clip Length	15 s
Target FPS	24 fps

PARAMETER	DEFAULT VALUE
Target Height Offset	0 m
Tilt Hold Strength	30
Tilt Joystick Expo	10 %
Tilt Joystick Smoothing	5
Tilt Joystick Window	8 $\mu$ s
Tilt Majestic Pan	135 deg
Tilt Smoothing	10
Tilt Stiffness	0
Tilt Trim	0
Tilt Window	5
Timelapse Interval	2 s



# APPENDIX B.

## DATA LOGGING FIELDS

FIELD	FIELD	DESCRIPTION
Accel East	m/s <sup>2</sup>	The IMU derived eastward acceleration
Accel North	m/s <sup>2</sup>	The IMU derived northward acceleration
Accel Up	m/s <sup>2</sup>	The IMU derived upward acceleration, without gravitational acceleration
Baro Height	m	Height derived by barometric pressure measurement
East	m	GPS measured positional change in the lateral axis; where positive values indicate movement to the East
GPS Alt	m	The altitude determined by received GPS signals
GPS Time	HH:MM:SS	The Universal Coordinated Time determined by received GPS signals
Hacc	m	Horizontal position accuracy reported by GPS
IMU Time	s	Measurement of time elapsed since IMU initialization
Lat	deg*10 <sup>7</sup>	GPS determined latitude multiplied by 10 <sup>7</sup>
Long	deg*10 <sup>7</sup>	GPS determined longitude multiplied by 10 <sup>7</sup>
North	m	GPS measured positional change in the longitudinal axis where positive values indicate movement to the North
Pitch	deg	The IMU derived pitch angle where positive values indicate pitch up
Pitch Rate	deg/s	The IMU derived pitch rate where positive values indicate an upward pitch
Radio Pitch	µs	RC pulse width (1000-2000µs) where increasing values are for pitch up
Radio Roll	µs	RC pulse width (1000-2000µs) where increasing values are for roll right
Radio Yaw	µs	RC pulse width (1000-2000µs) where increasing values are for yaw to the right
Roll	deg	The IMU derived roll angle where positive values indicate a roll to the right
Roll Rate	deg/s	The IMU derived roll rate where positive values indicate a rightward roll
Sacc	m/s	Horizontal speed accuracy reported by GPS
Sats	#	Number of satellites used for position calculation by GPS
Temperature	deg C	The IMU derived temperature inside the GCU
Up	m	Barometer measured positional change in the altitude; where positive values indicate rise in altitude
Vel East	m/s	The GPS derived eastward velocity component
Vel North	m/s	The GPS derived northward velocity component
Vel Up	m/s	The GPS derived upward velocity component
Voltage	V	Main battery voltage measured by the GCU
Yaw	deg	The IMU derived yaw angle where positive values indicate yaw in the clockwise direction
Yaw Rate	deg/s	The IMU derived yaw rate where positive values indicate a clockwise rotation

To download the most current user manual for the MōVI Pro and all other Freefly products, please visit <http://freeflysystems.com/software-manuals>



YouTube



@freeflysystems | #freeflyers